

# SCELZI ENTERPRISES

Product Catalog 2024-2025



*The Top-of-the-Line Since 1979*





# Spanning 45 Years of Innovation, Quality, and Commitment to Excellence

2024 marks our 45th year in business. It was 1979 when we first began turning our hobby into a business, welding trailers together for profit. Looking back over the years that followed, it is hard for us to believe how far we have come.



Mike and Gary Scelzi

As young men all three Scelzi brothers had a passion for cars and trucks. Mike, Jim, and Gary each spent time in related industries, but in the end they joined forces at Scelzi Enterprises to design and manufacture the best work truck bodies in the USA. Mike, the oldest, started by building cars in his garage. Today he still leads the Scelzi team. Youngest brother Gary spent a few years away from the business to win four National Hot Rod Association (NHRA) World Championships. He returned in 2008 to help his brothers build Scelzi Enterprises into a major force in the industry. Jim joined his brothers full time in 2006 after helping their father at his fuel distributorship. Jim retired from the business in 2018.

Their father Monroe Scelzi always believed his sons should be in business together, so he loaned the brothers \$20,000 so they could open the first Scelzi Enterprises manufacturing facility in 1979, on Thesta Avenue in Fresno. Since then the success of the company has caused them to expand many times, now in several Western states with future expansion to come. Driven constantly by an old-school pride in craftsmanship, the Scelzi attention to detail and commitment to making something better than anyone else is instilled into every member of their team.

Today the Scelzi Legacy continues, and our commitment to Quality is stronger than ever. As we fondly look back over the past 45 years, we are extremely grateful to the employees and key partners who helped us reach this moment in time.

*Don't Settle For Less Than A Scelzi!*

Our facilities make Scelzi Enterprises the largest manufacturer of truck bodies in the Western USA. Covering 25 acres in Southwest Fresno alone and including 450,000 square feet of office and manufacturing space, we employ more than 500 employees of various skills and talents to contribute to the Quality of our Trucks Bodies and our organization.





Our Annadale office building (far left) houses Engineering, Inside Sales, and other support departments. Behind it, the Annadale I production building focuses primarily on flatbeds. Over in Annadale II (far right), dump bodies, water trucks, and the most custom Scelzi body designs are welded and assembled.

The newest addition to the Fresno campus is the Elliott building (see below) on Cherry Avenue.

**FRESNO, CA**



It all started in a garage in Fresno, and then spread to a small building on Thesta Avenue. Today Scelzi Enterprises has California facilities in Fresno, Riverside, and Shafter, along with LaSalle (CO) and our newest facility in Tacoma, Washington!



**TACOMA, WA**





**RIVERSIDE, CA**

Wherever we are and whoever we select to join our team, we make sure the Scelzi Commitment to Quality is embedded deep into every product we manufacture, and in every person we employ.



**LaSALLE, CO**



**SHAFTER, CA**



## THE SCELZI ENTERPRISES MISSION STATEMENT

We utilize innovative truck body designs and an uncompromising Commitment to Quality to exceed our customer's expectations — providing value to our owners, our business partners, our team members, and our end users.



# Why Do Scelzi Truck Bodies Last Longer Than Other Bodies?



## 1 More Robust Design

Only Scelzi Truck Bodies Can Handle This Load



When you drive a SCELZI you can leave the tall ladder at home!



## 2 Premium Components



Thicker gauge steel for extended life



## 3 Precision Engineering, Welding and Assembly

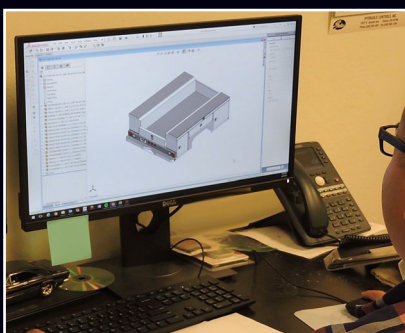

## SB - 98 - 79 - 49 - 38 - VO

	BODY TYPE	OVERALL BODY LENGTH	OVERALL BODY WIDTH	FLOOR WIDTH	COMPARTMENT HEIGHT	COMPARTMENT CONFIGURATION
WT	Water Truck Body	80"	79"	49"	33"	H - Horizontal Compartments with Close Tops
WCB	Western Crane Body					
CTFB	Contractor Body	98"	94"	54"	38"	V - Vertical Compartments with Close Tops
SCTFB	Super Contractor Body					
SB	Service Body SRW	108"	96"	56"	43"	HO - Horizontal Compartments with Open Tops
SBD	Service Body DRW					
SEC	Combo Body	132"			60"	VO - Vertical Compartments with Open Tops
SFB	Scelzi Flat Bed					
WFB	Western Flat Bed	156"				<p>It is assumed both sides of the truck body have the same configuration unless noted. See the next page for details -&gt;</p>
FBC	Flatbed - Custom					
FRFB	Front Range Flatbed					
SBCR	Crown Service Body, SRW					
SBD CR	Crown Service Body, DRW					
SBD CRH	Crown RV Hauler Body					



### Compartment Configuration

H - Horizontal Compartments with Close Tops

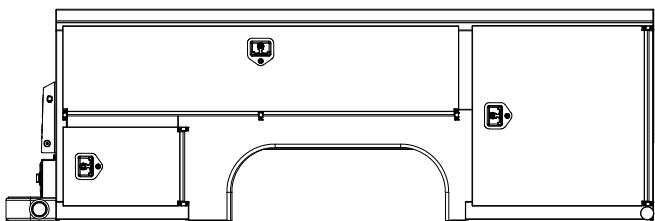

V - Vertical Compartments with Close Tops

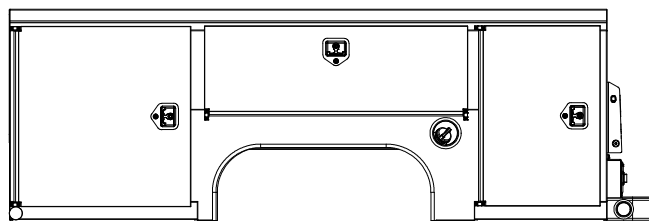

HO - Horizontal Compartments with Open Tops

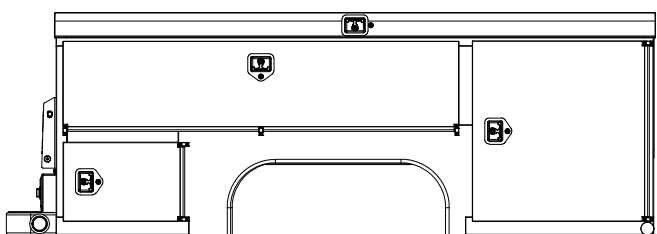

VO - Vertical Compartments with Open Tops

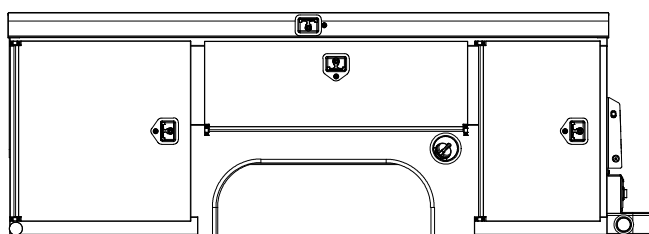

## Driver's Side

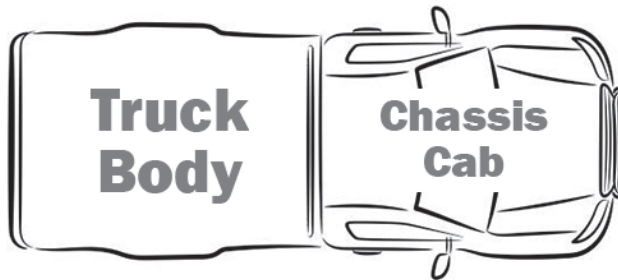

Unless specified, it is assumed the compartment configuration is the SAME on both sides of the body:

The Driver's Side and the Passenger Side.

## Passenger Side (sometimes called "curbside")



## Driver's Side

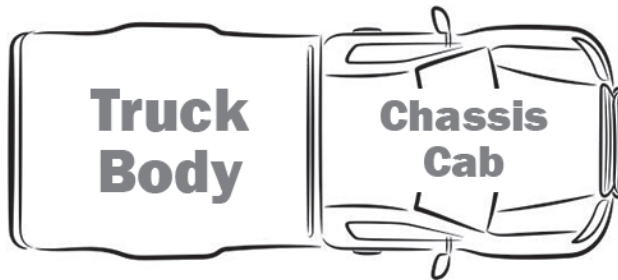

## Passenger Side (sometimes called "curbside")

Unless specified, it is assumed the compartment configuration is the **SAME** on both sides of the body.

If there is a difference, the Driver's Side configuration is always listed first.

SERVICE BODY EXAMPLE:

**SB-98-38-VO**

Indicates Vertical Open Top compartments on **BOTH** the Driver and Passenger side

but

**SB-98-38-VO-V**







Indicates Vertical Open Top compartments on Driver's Side but Vertical Closed Top compartments on the Passenger side







# The World's Best Truck Bodies

	<b>Flatbed/Platform</b>	WESTERN Flatbed SCELZI Flatbed	Page 10
	<b>Landscaper/Gardener</b>	8 x 10, 8 x 12, and 8 x 14 feet long	Page 13
	<b>Cowboy</b>	7 x 8, 8 x 8, and 8 x 9 feet long	Page 14
	<b>Front Range Flatbed</b>		Page 15
	<b>RV Hauler</b>		Page 16
	<b>Contractor</b>	7 x 9, 8 x 10, 8 x 12 and 8 x 14 feet long	Page 17
	<b>Super Contractor</b>	8 x 12/14 foot Contractor Body with extra storage capacity	Page 18
	<b>Combo</b>	9, 10, 12, and 14 feet long	Page 19
	<b>Service</b>	SIGNATURE Service Body Service Body Insert	Page 25
	<b>Super Structure</b>	For 8600 GVW and higher	Page 34
	<b>Crane</b>	Western Crane Body 11 feet long	Page 35
	<b>Welder</b>		Page 36
	<b>Dump</b>		Page 37
	<b>Chipper</b>	12, 14, and 16 feet long	Page 42
	<b>Water Truck</b>	2000, 2500, and 4000 Gallon Tanks	Page 44
<b>Parts and Accessories</b>	<b>Parts and Accessories</b>		Page 49
<b>SCELZI CLASSICS: Special Order Designs</b>	<ul style="list-style-type: none"> <li>• A-Frames</li> <li>• Crane Body - Non Western</li> <li>• Contour Body</li> <li>• Cruiser Body</li> </ul>		Page 57
<b>CUSTOM DESIGNS</b>			Page 59

# FLATBED Bodies



## Common Styles

Scelzi Flatbed bodies are available in several different styles:

1. Scelzi Flatbed - with an "angled" tail plate and California Dock Bumper in back.
2. Western Flatbed - with a "squared" ICC Dock Bumper in back.
3. Flatbed Dump with hoist
4. Custom Flatbed



Western Flatbed



Scelzi Flatbed



Flatbed Dump



Custom Flatbed (pg 59)

## Recent Classics

WO# 249519



WO# 216541



WO# 239116



WO# 252157



## Common Features and Options

### Available for Scelzi and Western Flatbeds

- Underbody Tool Box - See table below for options
- Top Mounted Tool Box - Closed Top  
Available in 72", 96" and 108" long  
18" high - 18" deep
- Top Mounted Tool Box - Open Top  
Available in 48", 72", 96" and 108" long  
18" high - 18" deep

### Side Racks

- A.J. Baer style tapered polished stainless steel stakes with slats. See photos below.  
Available in 12", 15", 18", 24", 36", 42", 48" heights.
- Other combinations of painted steel stakes or hardwood, steel or aluminum siding can be ordered.



### Scelzi Flatbed Underbody Tool Boxes

LONG	HIGH	DEEP
24"	18"	18"
30"	18"	18"
36"	18"	18"
40" *	18"	18"
48"	18"	18"
60"	18"	18"

\* This is a special order item

A.J. Baer Style Tapered Stainless Steel Stakes



Optional Tie Down Rail

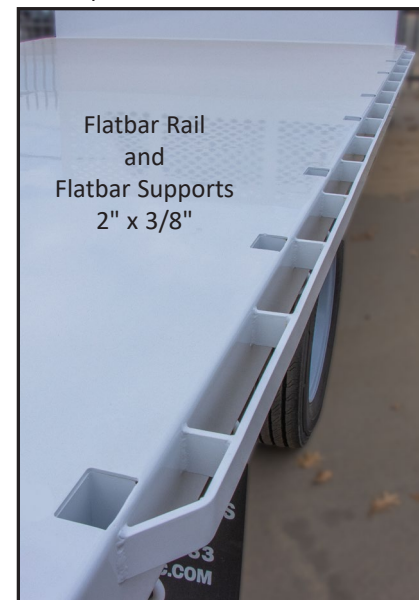



Photos may contain optional equipment - verify your specifications when you order.

## Standard Body Lengths and Specifications

Available 10', 12', 14' and 16' Long

### CHOICE OF DECKING MATERIAL:

- 7/8" Aluminum Decking
- 7/8" or 1-1/8" Wood Decking
- 3/16" Smooth Steel
- 3/16" Diamond Plate
- Cross Member on 12" Centers
- Rope hooks on Each Cross Member
- Head Board 10 Gauge 12" x 24" Window
- ICC Bumper

### HOIST:

Scelzi Electronic and PTO Hoists Available

### SIDE RACKS:

- A.J. Baer Stainless Stakes with 3/4" Wood Material
- Solid or with a Gap
- 12", 15", 18", 24", 36", 42" or 48" Tall
- 1/2" Plywood Side Racks with Capping, Painted White or Black, 12", 15", 18", 24", 36", 42" or 48" Tall
- Removable Steel A.J. Baer Stakes with 18 Gauge Steel Slats Corrugated Painted White or Black
- 12", 15", 18", 24", 36", 42" or 48" Tall
- Non Removable Steel Side Racks 12" or 24" Tall, 10 or 14 Gauge

### BARN DOORS:

- Door Gates with Western Gate Latches for 12" or 24" Tall Doors
- Door Gates with or without Optional Cross Bars 8" Above Door.
- 36", 48" or 60" Tall Doors

### BINDER:

- Combo binder
- Recessed Combo Binder
- Sliding binder
- 3/4 Rope Hooks

### DUMP BED RECEIVER HITCHES:

- 1,000# Tongue Weight - 10,000 Pull Weight - Class 4
- 1,800# Tongue Weight - 18,000 Pull Weight - Class 5

### HITCHES FOR HEAVIER DUTY TOWING

- Recommended for 550 or Lower: PH 15 - Pintle hitch with 1/2" Buck Plate or A-Frame
- Recommended for 650 and Above: 580J Premier H.D. Pintle 3/4" with Buck Plate





Photos may contain optional equipment - verify your specifications when you order.

## Standard Body Lengths and Specifications

Series	Bed Size	Side Rack Package Options
14.4	8 ft x 10 ft	Package A: 42" Solid steel with a HINGED horizontal door 69" wide, OR Package B: 42" Solid steel with a front vertical door 46" wide, OR Package C: 42" Solid steel with dual fold down doors Special Order: 1/2" Removeable plywood racks with steel stakes, western gate latches
11.2	8 ft x 12 ft	
9.2	8 ft x 14 ft	

### Standard Features

- 10 Gauge Smooth Steel Floor
- Cross Member on 16" Centers with Rope hooks on Each Cross Member
- Rear Barn Doors and Optional Side Barn Doors
- 42" Solid Steel side racks hinged to fold out at 21"
- Racks in approximately 5 ft sections - One in front, one on driver side, and one curbside (passenger side)
- Class V Receiver hitch and 7/4 RV plug
- Cargo area covered with Polyurea for added Rust/ Corrosion protection
- **HOIST:** Double Acting Scelzi Hoist. See page 37 for more hoist information



**Package A**

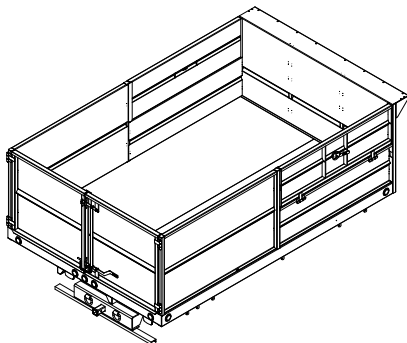
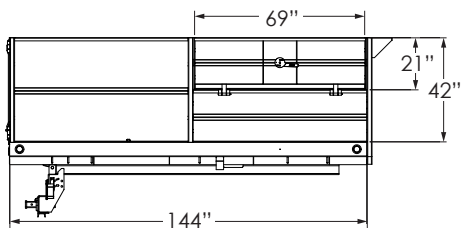

**Package B**

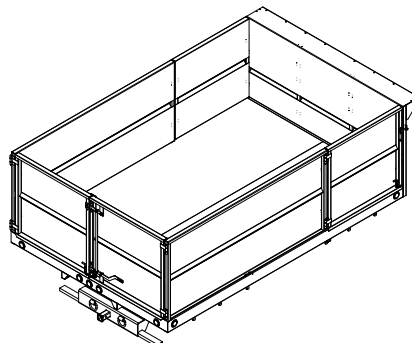
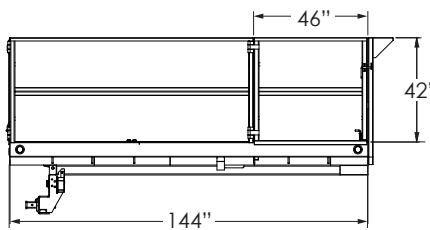

**Package C**

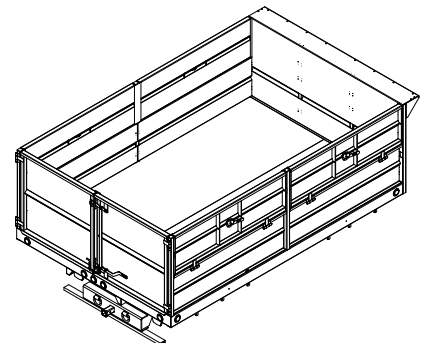
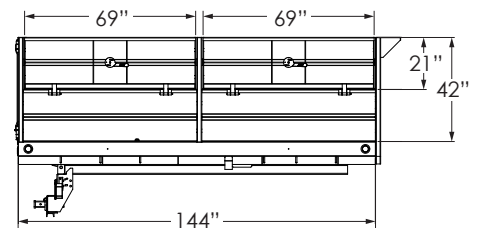



Photos may contain optional equipment - verify your specifications when you order. Body Sizes:

**Flooring Choices:**

- Standard flooring options are hardwood or diamond plate steel

- 7 ft x 8 ft
- 8 ft x 8 ft, as shown in photos with steel flooring and 6" fold down side racks
- 8 ft x 9 ft body is also available

## Standard Specifications

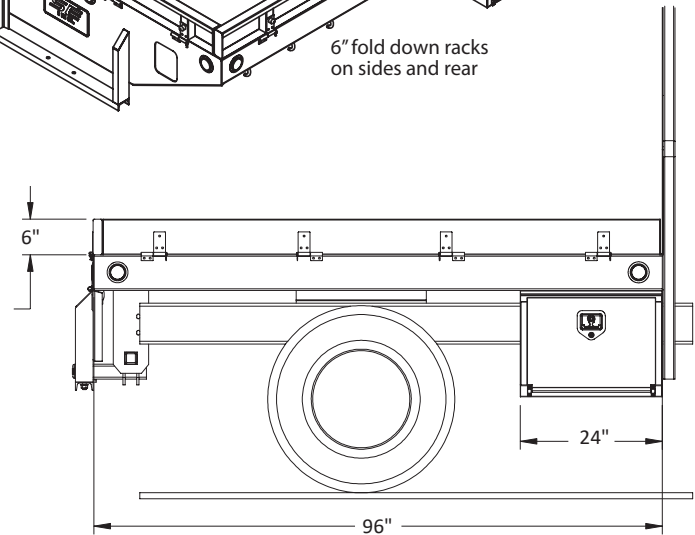
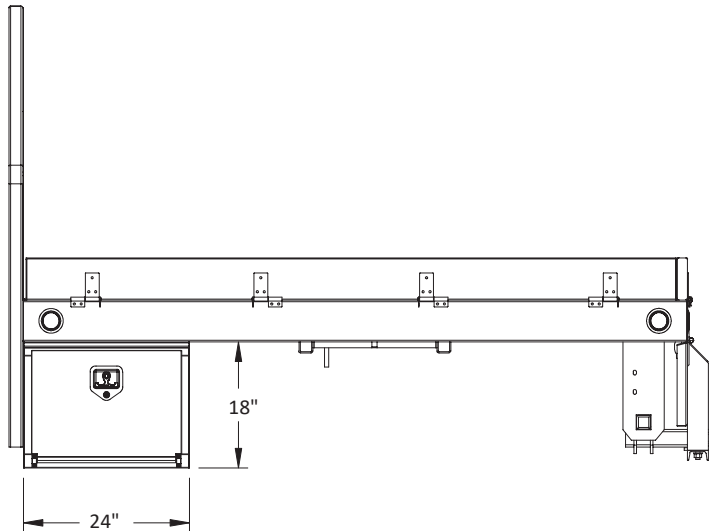
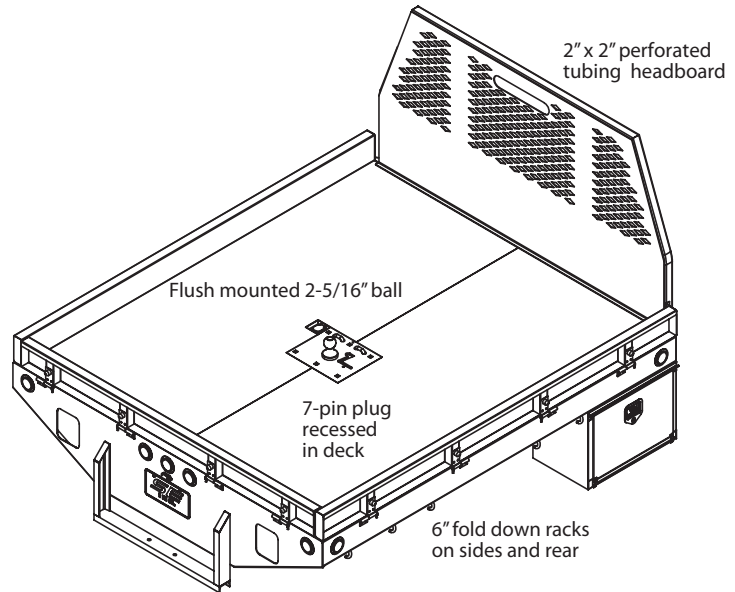
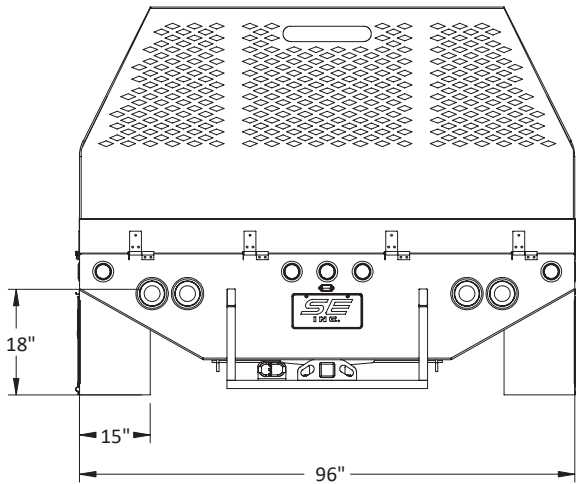



Integrated gooseneck hitch with 2-5/16" ball plus side flip lid.

*Photos may contain optional equipment verify your specifications when you order.*

## Standard Body Lengths and Specifications

Bed SIZE	Cab to Axle (CA)	Rear Wheel	Hitch	Tool Boxes
7 ft x 8.5 ft	56"	Single	Factory hitch and 7 way RV plug	30" Long x 18" High x 12" Deep tool box installed in front of rear wheels
8 ft x 8.5 ft	56"	Dual	Factory hitch and 7 way RV plug	30" Long x 18" High x 18" Deep tool box installed in front of rear wheels
8 ft x 9.5 ft	60"	Dual	Scelzi Class 5 hitch and 7 way RV plug	36" Long x 18" High x 18" Deep tool box installed in front of rear wheels
8 ft x 11.5 ft	84"	Dual	Scelzi Class 5 hitch and 7 way RV plug	48" Long x 18" High x 18" Deep tool box installed in front of rear wheels

### Standard Equipment For All Sizes

- 1/8" Diamond Plate Cargo Floor & Sides
- Rear and Front 1/8" smooth steel tail plate w/6" tapered corners @ rear
- Front smooth steel 6" rail
- 4" x1/8" formed cross-members 6" integrated thick
- Longsills AJ Baer tapered stake pockets sides & rear
- Bolt-on tapered head board with LED seal
- Beam lights built into top corners of headboard – stop, turn, tail and back-up
- Rear tail apron with custom ICC Dock
- Bumper LED lights – stop, turn, tail and back-up
- Camera – installation
- All LED marker lights
- Integrated goose neck hitch with 2 5/16 ball recessed in floor with slide flip lid with 7 way RV plug #12707
- 1/2" Rope hook installed
- Black powder coated

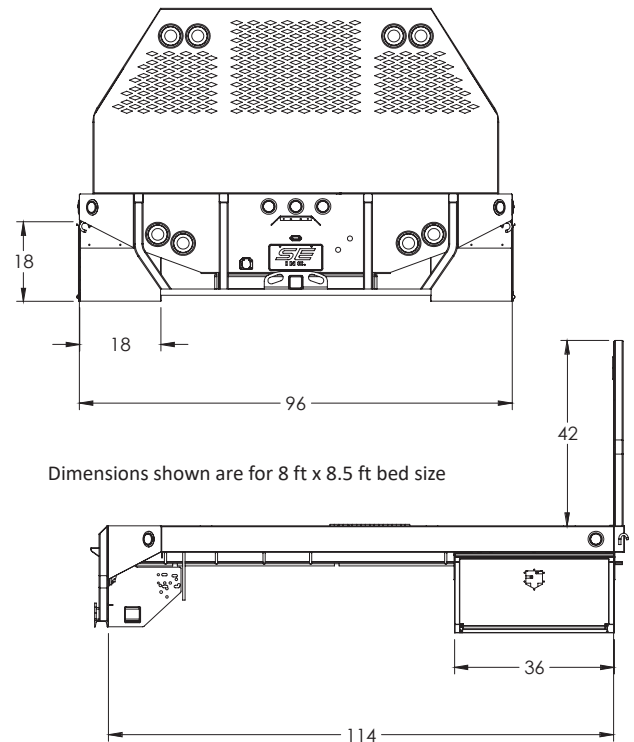



Photos may contain optional equipment - verify your specifications when you order.

## Standard Body Lengths and Specifications

### Body Length:

- 108 inches

### Options

- Hitch can be B&W turn over ball 1500R.

### Available Models:

- VO - Vertical Compartments with open tops.
- V - Vertical Compartments with close tops.

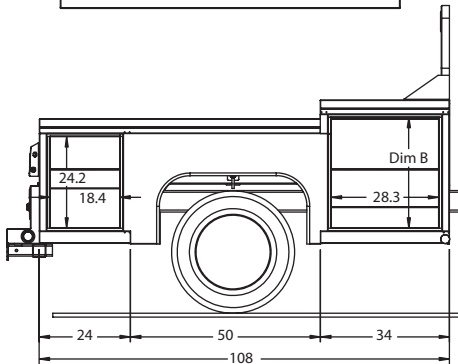
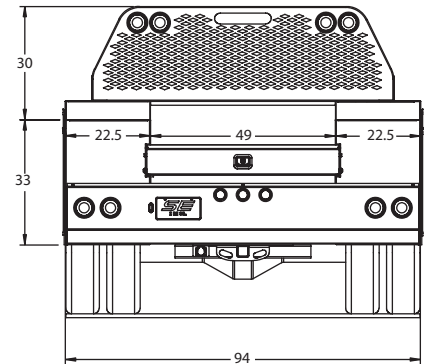
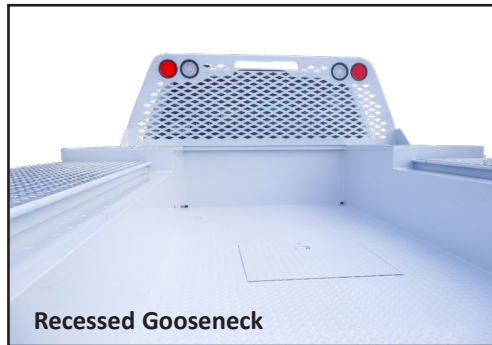
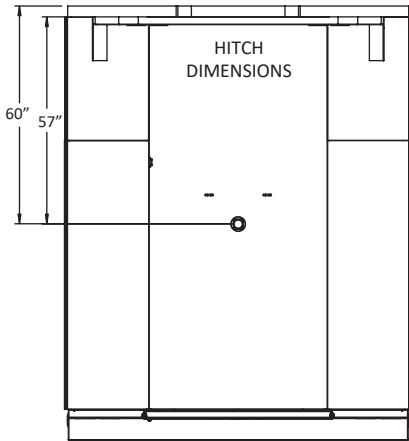
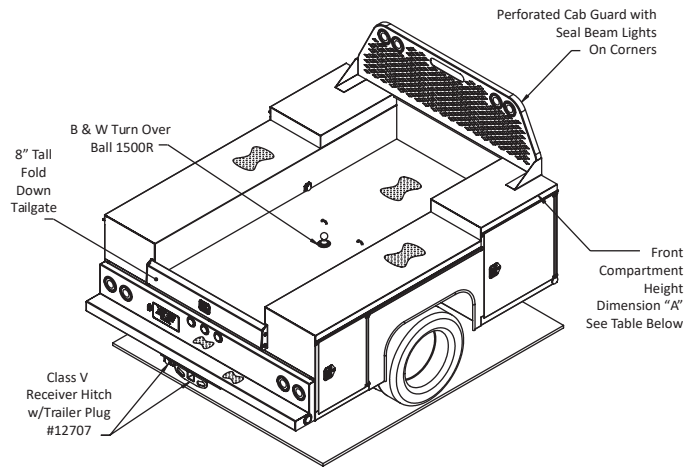

Model	Hitch Type Configuration	Dimensions	
		A	B
A	Recessed Gooseneck, shown above	33	24.2
B	B&W Turn Over Ball 1500R	33	24.2
C	B&W Turn Over Ball 1500R	38	29.3
D	Recessed Gooseneck, shown above	38	29.3



# CONTRACTOR FLATBED Bodies



Photos may contain optional equipment - verify your specifications when you order.

## CTFB-8/12 (84 CA) Standard Specifications

Other Widths/Lengths Available: 7/9 • 8/10 • 8/14

### Body Dimensions:

- 8 ft Wide x 12 ft Long (144 inches)
- Other Bodies Available:
  - 7 ft Wide X 8.5 ft Long (108 inches) - 56 CA
  - 8 ft Wide X 10 ft Long (120 inches) - 60 CA
  - 8 ft Wide X 14 ft Long (168 inches) - 108 CA

### Color:

- White

### Flooring/Rack Choices:

- Wood floor and fold down side racks
- OPTIONAL: Aluminum floor and fold down side racks

### Tool Boxes:

- 96" x 18" x 18" top mount, open top (2 boxes)
- 60" x 18" x 18" underbody (2 boxes)

### Top Rack:

- Removeable 3" x 2" x 120" wall with 2" legs and
- 3" x 2" removeable crossbars
- Powder coated
- OPTIONAL: Standard or fork lift accessible material rack
- NOTE: No warranties offered on wood products



This photo shows CTFB-8/10

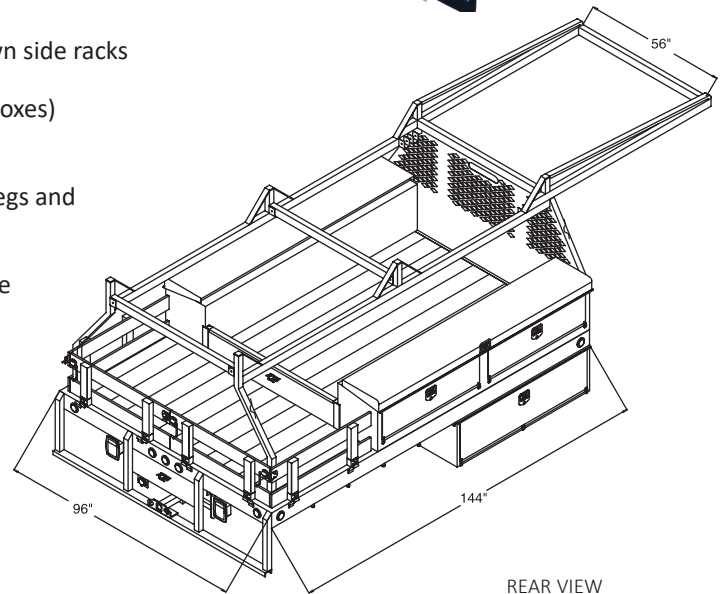

15" FOLD DOWN SIDE RACKS  
STAINLESS STEEL STAKES

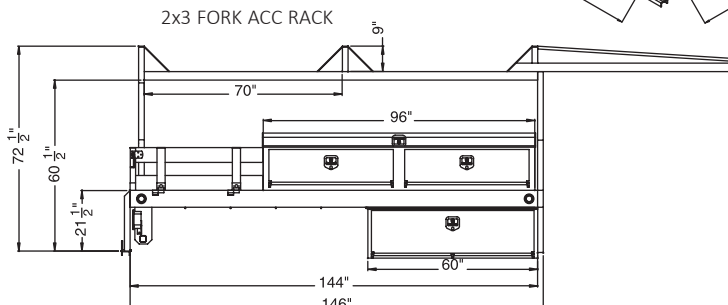
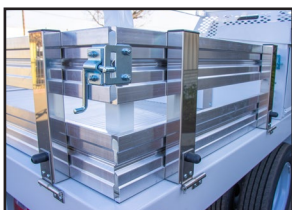

REAR VIEW

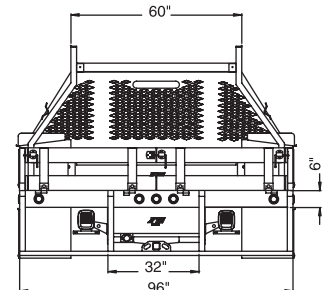

All drawings reflect dimensions for the most popular applications

# SUPER CONTRACTOR FLATBED Bodies



Photos may contain optional equipment - verify your specifications when you order.

## SCTFB-8/12 (84 CA) Standard Specifications

- Body Dimensions:**
- 8 ft Wide x 12 ft Long (144 inches)
  - 8 ft Wide x 14 ft Long also available
- Color:**
- White
- Flooring/Rack Choices:**
- Wood floor and fold down side racks
  - OPTIONAL: Aluminum floor and fold down side racks
- Tool Boxes:**
- 96" x 30" x 20" top mount, closed top (2 boxes)
  - 96" x 13" x 20" Shovel box - full length opening
  - 60" x 18" x 18" underbody (2 boxes)
- Compartments:**
- Bottom compartments with 1 roller drawer and 1 adjustable shelf on each side
- Top Rack:**
- Removeable 3" x 2" x 120" wall with 2" legs and 3" x 2" removeable crossbars
  - Powder coated
  - OPTIONAL: Standard or fork lift accessible material rack
  - NOTE: No warranties offered on wood products



Standard Item In Boxes For This Model Only



15" Fold Down Side Racks With Aluminum Slats and Stainless Steel Stakes

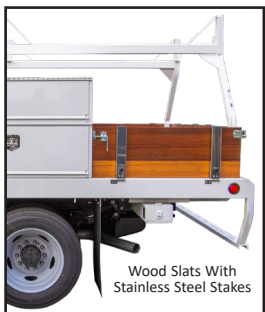

Wood Slats With Stainless Steel Stakes

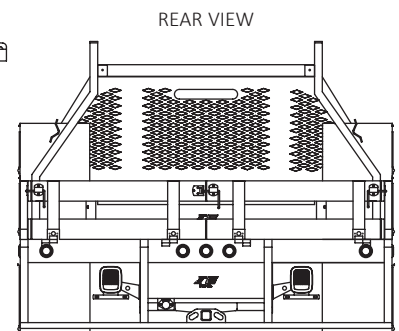
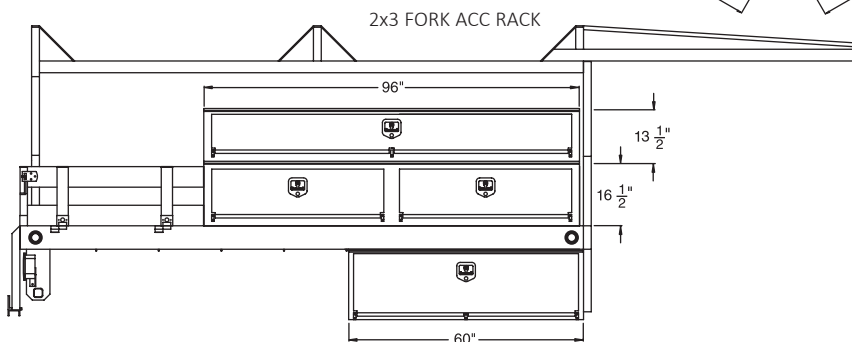
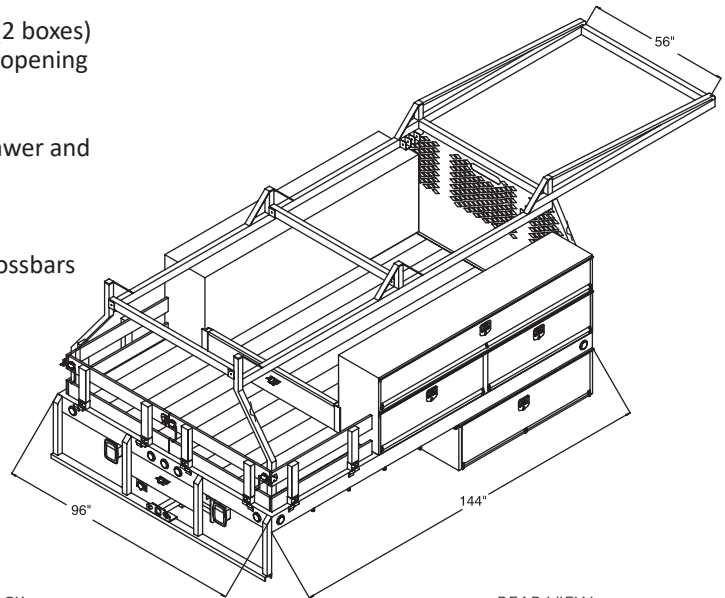

# COMBO Service Bodies



Photos may contain optional equipment. Verify your specifications when you order.

**SEC-144 12 ft (84 CA) Standard Specifications**

**Other Widths/Lengths Available: 9 ft • 10 ft • 14 ft**

- Body Dimensions:**
- 144 inches Long (12 ft) x 94 or 96 inches Wide
  - Other Bodies Available:
    - SEC-110 9 ft Long - 56-60 CA
    - SEC-120 10 ft Long - 60 CA
    - SEC-168 14 ft Long - 108 CA
- Rear Wheel:**
- Dual
- Color:**
- White
- Side Racks:**
- Steel floor with wood fold down side racks
  - OPTIONAL: Aluminum fold down side racks
- Storage Compartments:**
- Aluminum diamond plate on top
  - Height: 38 inches high
- Top Rack:**
- Powder coated ladder rack

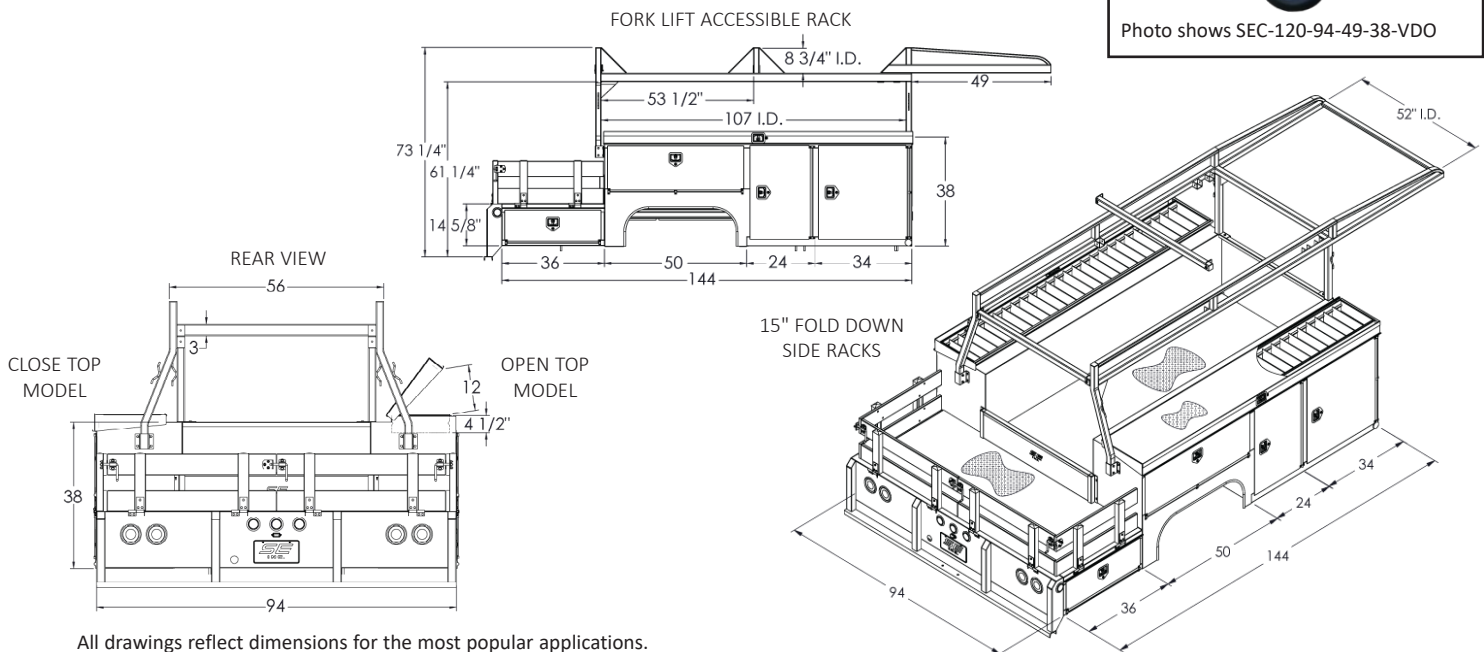

All drawings reflect dimensions for the most popular applications.

# Combo Body Configuration Options



**SEC-144-94-49-33-VD Closed Top**

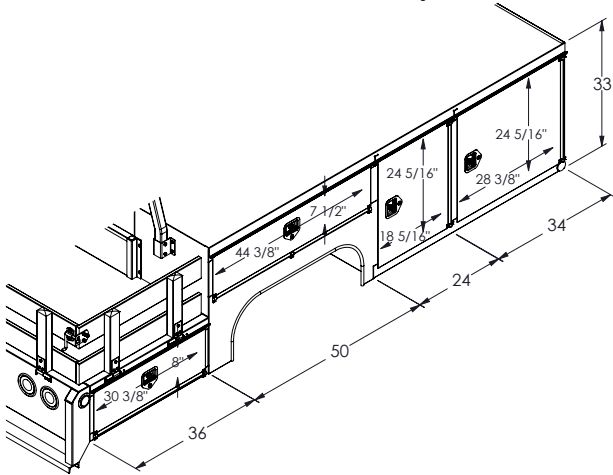

**VDO Open Top**

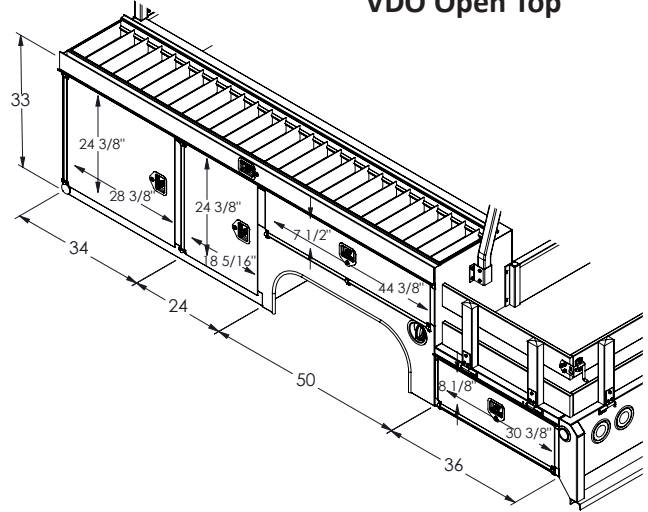

**SEC-144-94-49-38-VD Closed Top**

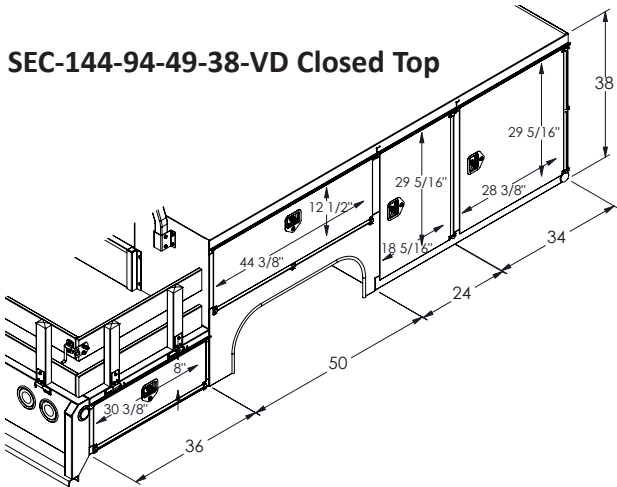

**VDO Open Top**

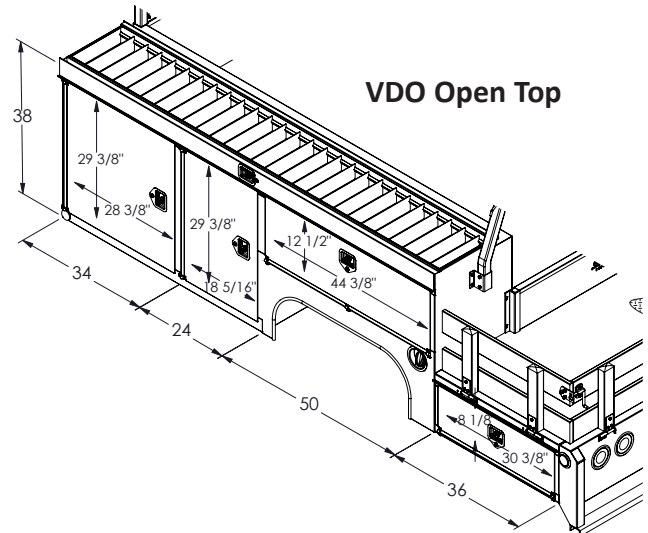

**SEC-144-94-49-43-VD Closed Top**

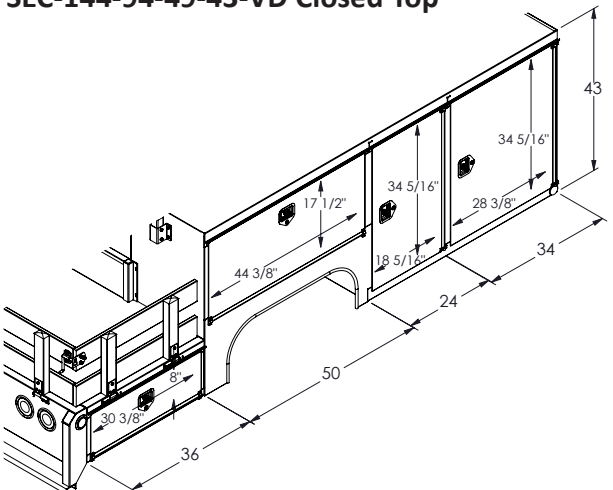

**VDO Open Top**

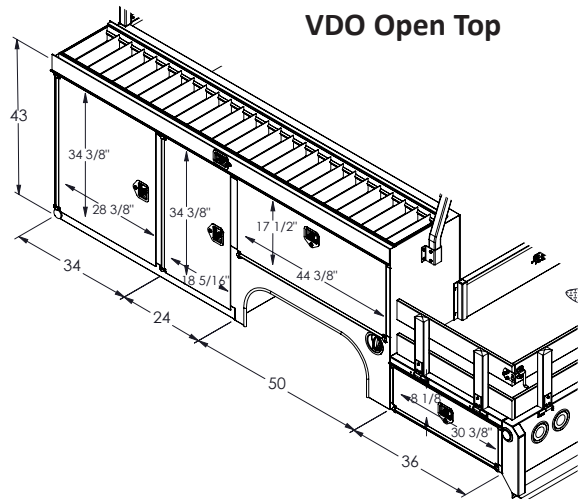

# Combo Body Configuration Options



**SEC-144-94-54-33-VD Closed Top**

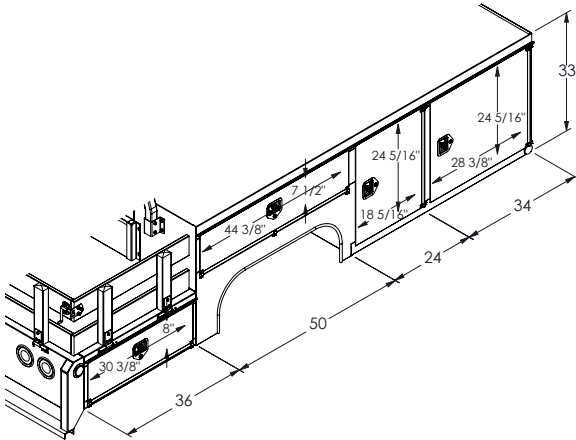

**VDO Open Top**

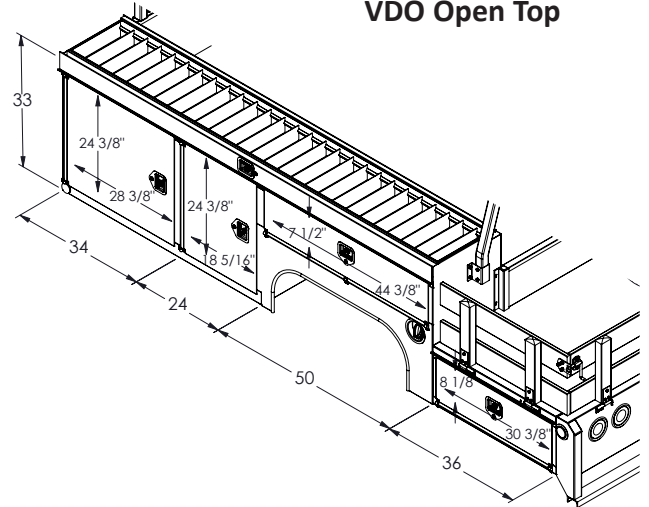

**SEC-144-94-54-38-VD Closed Top**

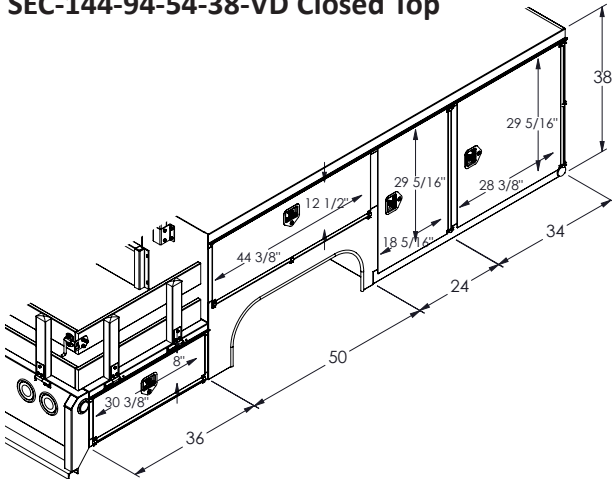

**VDO Open Top**

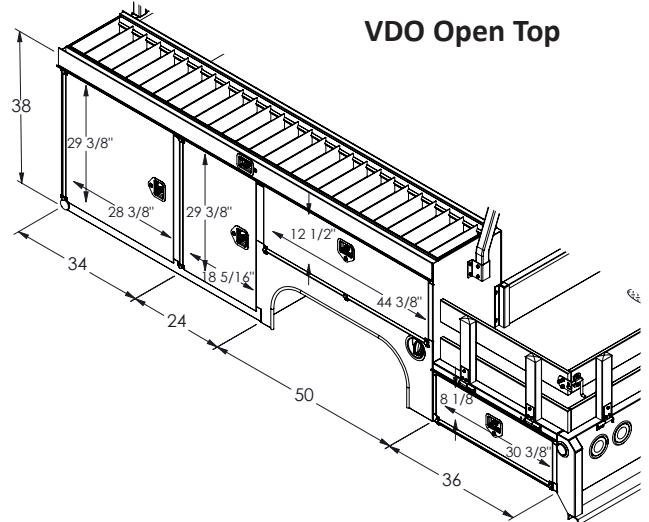

**SEC-144-94-54-43-VD Closed Top**

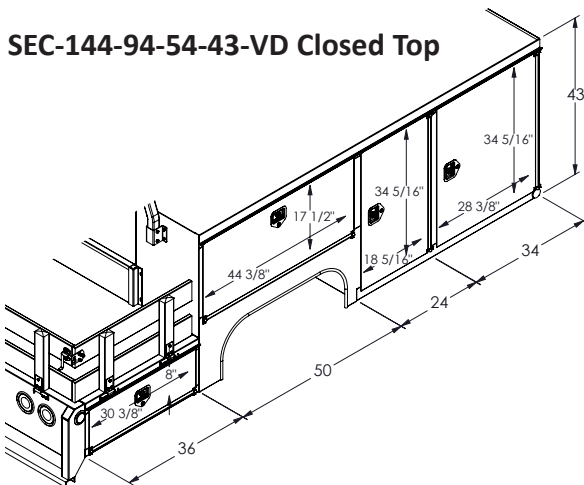

**VDO Open Top**

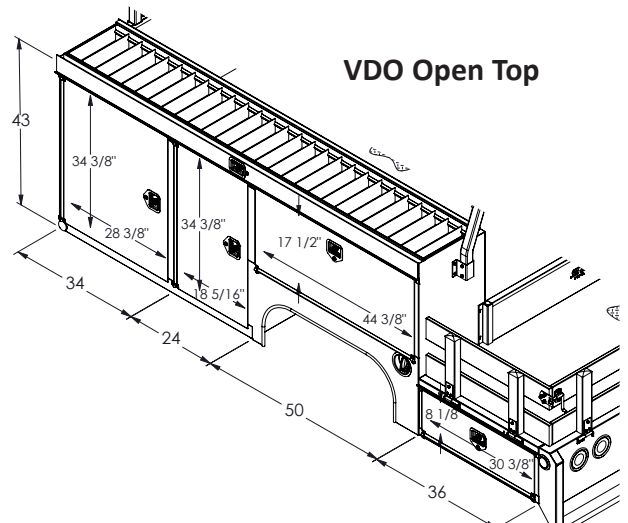

**SEC-110-79-49-38-VD  
Closed Top**

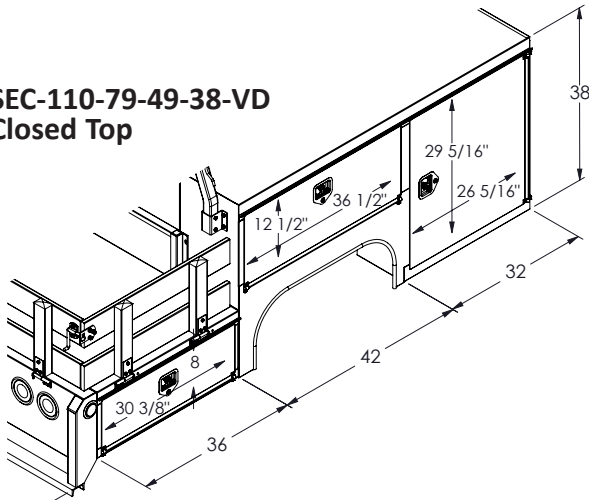

**VDO Open Top**

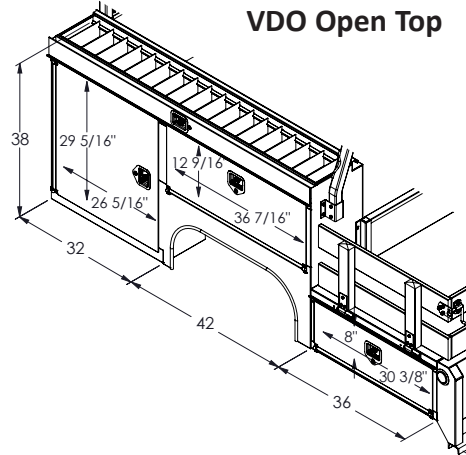

**SEC-120-79-49-38-VD  
Closed Top**

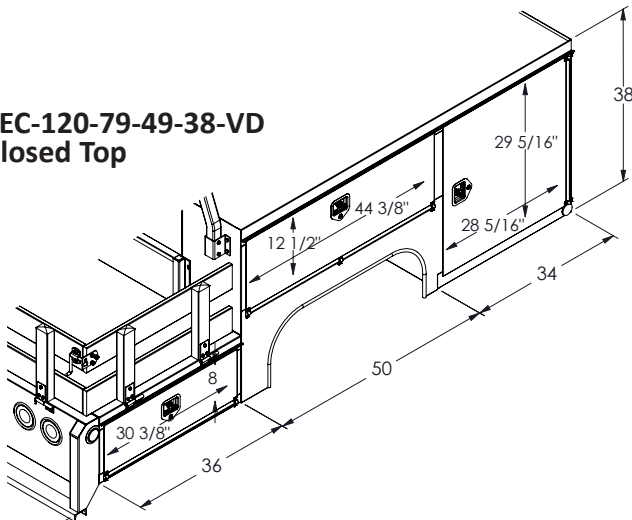

**VDO Open Top**

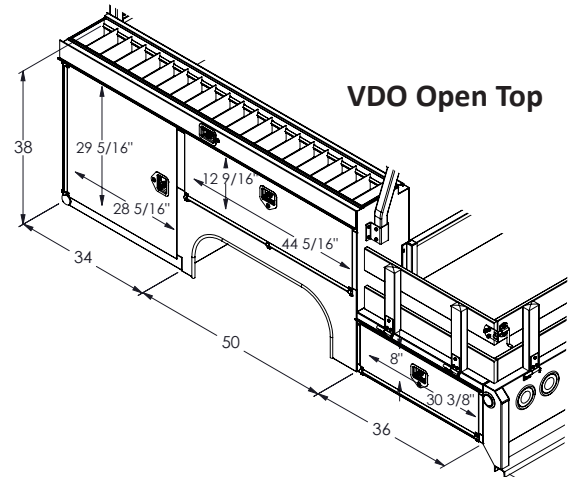

# Combo Body Configuration Options

**SEC-168-94-49-38-VD**  
Closed Top

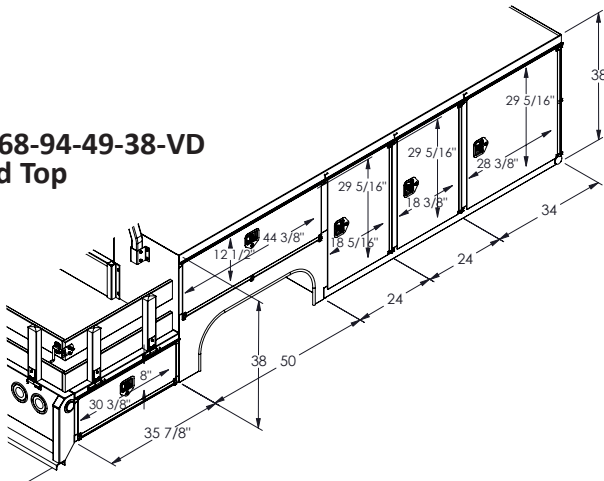

**VDO Open Top**

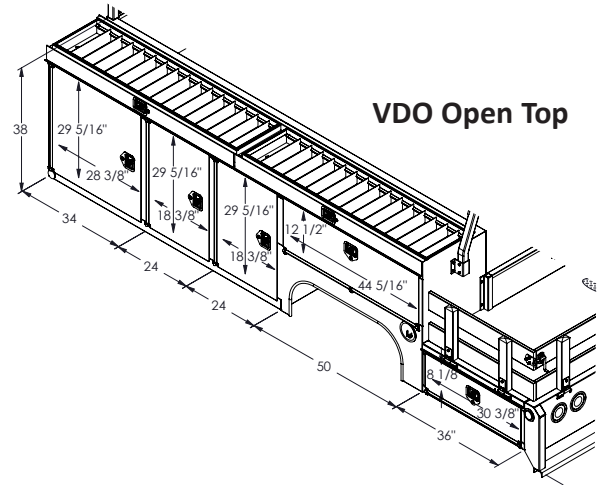

**SEC-144-94-49-38-VD**  
Closed Top

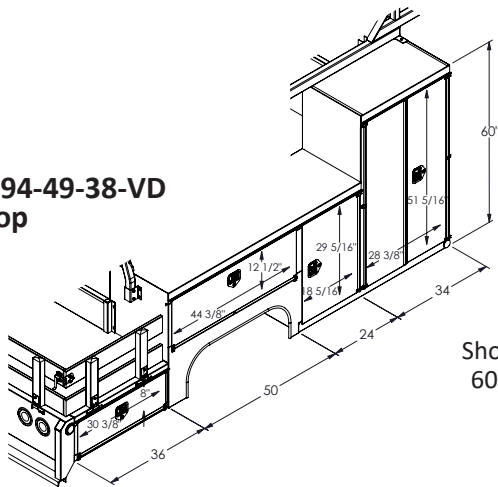

**VDO Open Top**

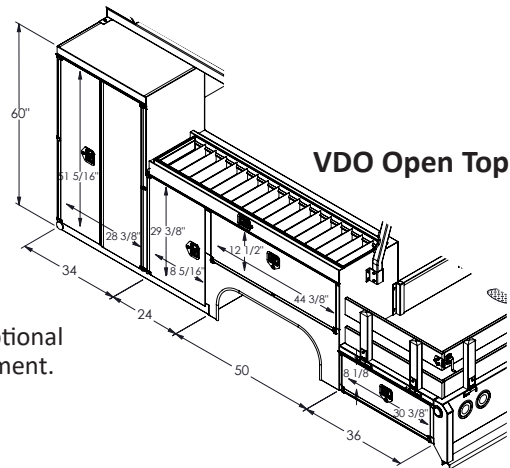

Shown here with optional  
60" x 34" compartment.

# Standard Features On All Scelzi Signature Truck Bodies



Open tops - open top lids of 16 gauge galvanized metal with smooth tops, "Z" style hat section, using 18 gauge inner panel, with aluminum diamond plate overlay. Scelzi Enterprises has the strongest open tops in the industry. Heavy duty gas shocks 2 per open top for easy door opening. 4 1/2" deep open top tray.

Doors - double panel door 18 gauge outer, 20 gauge inner laminated together for greater durability "Z" style hat section for extra strength. Doors mounted using stainless steel hinge block with nylon insert, stainless steel self sealing mono bolt, and 5/16 stainless steel full length door shaft.



Door Seals - Special design contour - Neoprene seal inside the door.

1/8 x 1/2 rubber stops the door from chaffing against the body.

Gas shocks on open top compartments and vertical doors.

Tailgate - heavy duty self leveling tailgate with 12 gauge diamond plate inner panel and 1/4" stainless steel end cap.

Stainless steel hinge block with nylon insert



Tailgate bracket - 10 gauge stainless steel.

Scelzi Signature Service Body Is Shown

Shelves - 16 gauge galvanized with return flange curl. Shelf brackets are 12 gauge galvanized.

Shelves are Heavy duty lock-in-place

All vertical compartments have 2 adjustable shelves, horizontal compartments have 1 adjustable shelf

All shelves are adjustable on 2" centers

Three point latching system on all compartment doors.

Tail hinges on 5/8" stainless steel Allen Head Shoulder Bolt with 5/8" Bronze Bushing.

Seal-beam type tail, clearance and back-up lights.

All bodies equipped with a six-inch step bumper. Powder coated grey.

Superior underbody construction using thicker gauge steel and more cross-members than other truck body builders

## Additional Signature Body Features:

- Six-point mounting on 8 and 9 foot bodies. Eight point mounting on 11 and 13 foot bodies.
- All beds are caulked with Ultra Neoprene sealers, and the underside of the bed and wheel wells are under-sealed before the bed is installed
- Multiple coats of primer and urethane paint are added for longest durability

Chrome Scelzi T-Bar handle latches with polished rivet-free stainless steel pockets and Galvanized steel locking rods



All compartment doors equipped with barrel locks

Three-year bulkhead to bumper warranty





## Work Decks

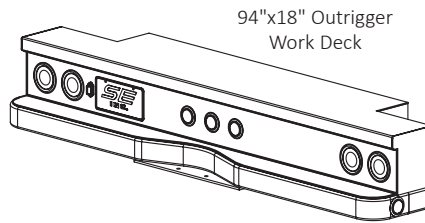

94"x18" Outrigger Work Deck

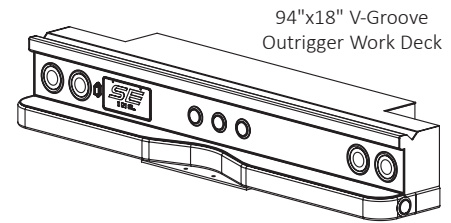

94"x18" V-Groove Outrigger Work Deck

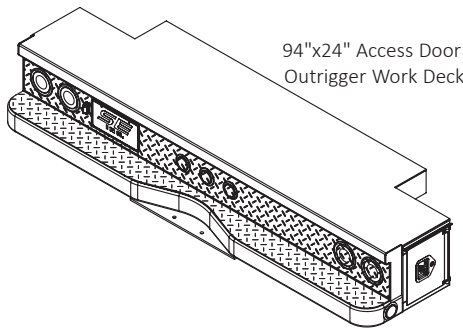

94"x24" Access Door Outrigger Work Deck

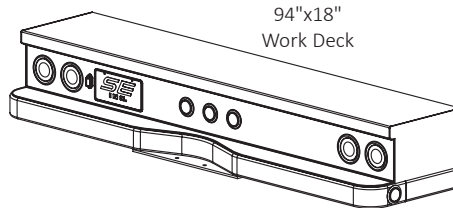

94"x18" Work Deck

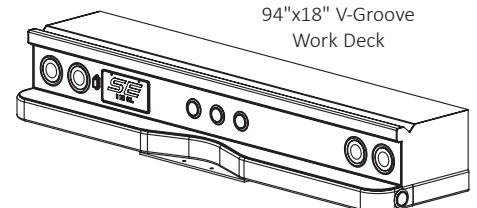

94"x18" V-Groove Work Deck

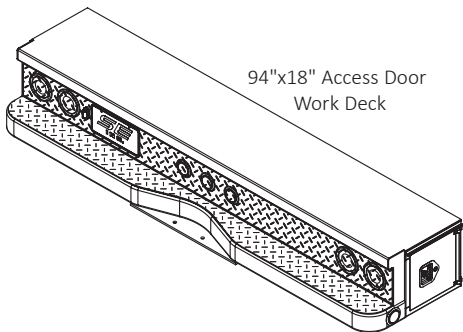

94"x18" Access Door Work Deck

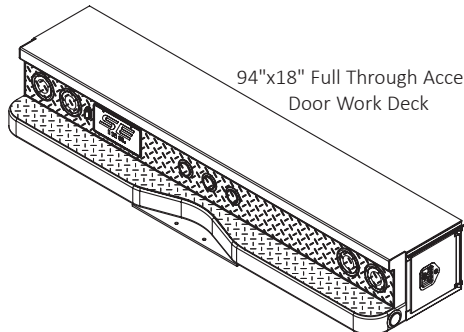

94"x18" Full Through Access Door Work Deck

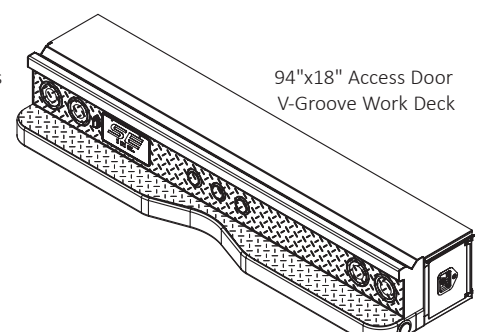

94"x18" Access Door V-Groove Work Deck

## Bumpers

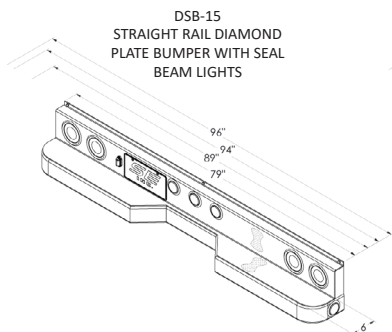

DSB-15  
STRAIGHT RAIL DIAMOND  
PLATE BUMPER WITH SEAL  
BEAM LIGHTS

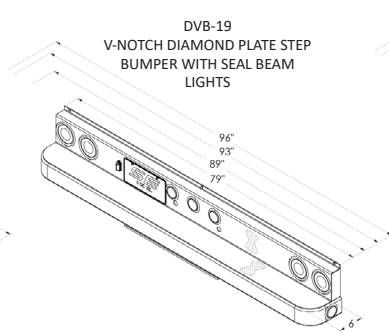

DVB-19  
V-NOTCH DIAMOND PLATE STEP  
BUMPER WITH SEAL BEAM  
LIGHTS

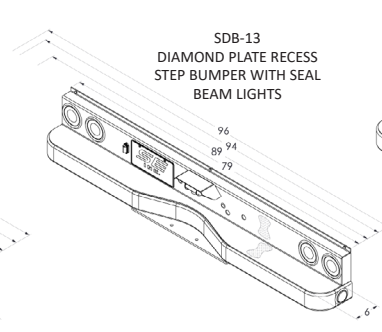

SDB-13  
DIAMOND PLATE RECESS  
STEP BUMPER WITH SEAL  
BEAM LIGHTS

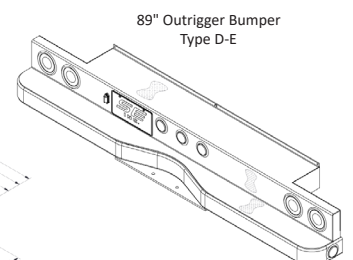

89" Outrigger Bumper  
Type D-E

Other bumper style options available, but not shown



## SINGLE REAR WHEEL

## Standard Specifications

### Body Dimensions Available:

SB-80	80 Inches Long x 79 Inches Wide	40 CA
SB-98	98 Inches Long x 79 Inches Wide	56 CA
SB-108	108 Inches Long x 79 Inches Wide	60 CA

**Compartment Height:** 38 inches high is standard  
Options: 33 and 43 inch high compartments are available as a special order.

**Rear Wheel:** Single

**Color:** White

**Storage Compartments:** Aluminum diamond plate on top  
See page 31 for tool box configuration options

**Optional Top Rack:** Powder coated over the cab contour material rack

Style	Orientation	Tops
VO	Vertical	Open
HO	Horizontal	Open
V	Vertical	Closed
H	Horizontal	Closed



## SB-80 Most Common Dimensions (SB-80-79-49-38-VO)

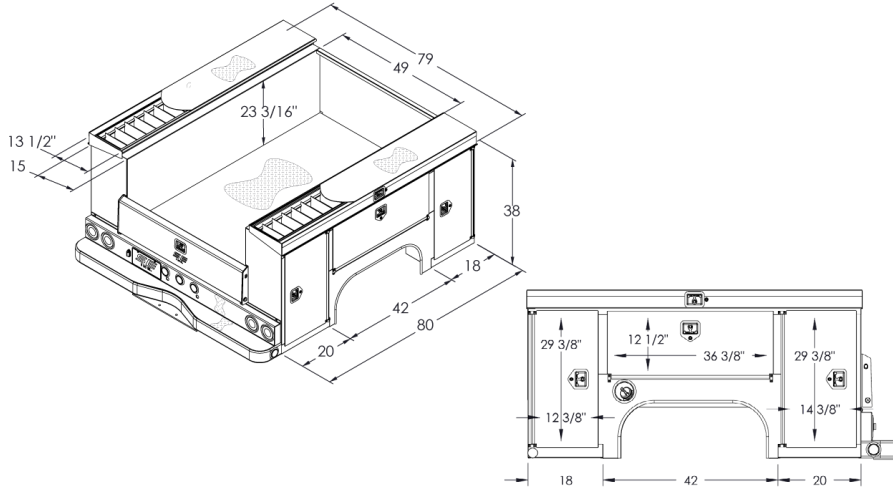

## SB-98 Most Common Dimensions (SB-98-79-49-38-VO)

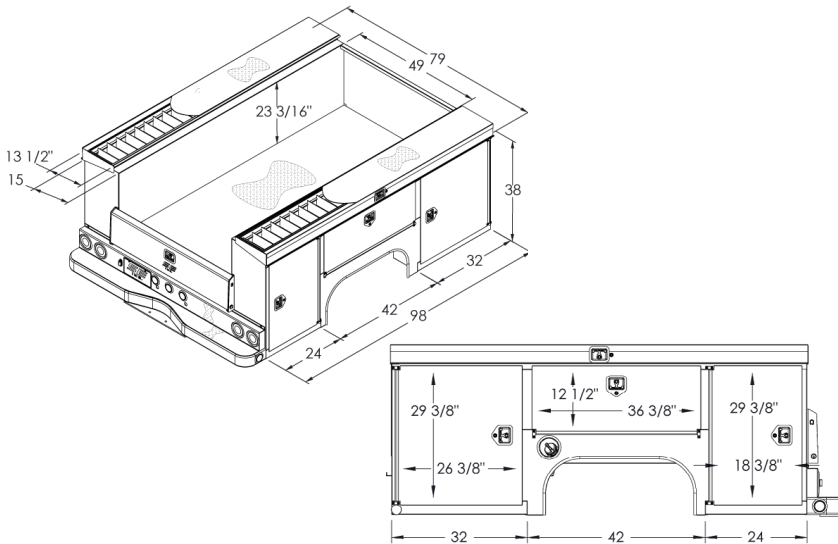

## SB-108 Most Common Dimensions (SB-108-79-49-38-VO)

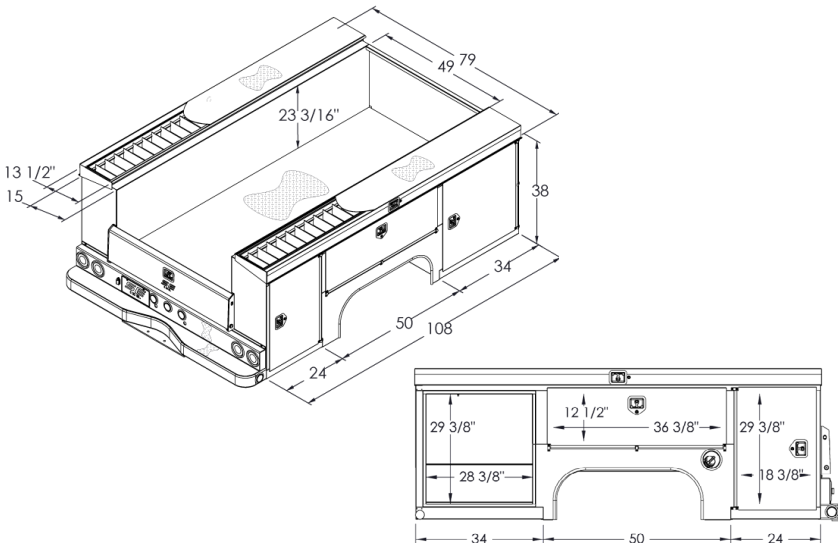



Photos may contain optional equipment - verify your specifications when you order.

## DUAL REAR WHEEL

## Standard Specifications

Body Dimensions Available:	SBD-98	98 Inches Long x 96 Inches Wide	56 CA
	SBD-108	108 Inches Long x 94 Inches Wide	60 CA
	SBD-132	132 Inches Long x 94 Inches Wide	84 CA
	SBD-156	156 Inches Long x 94 Inches Wide	108 CA

**Compartment Height:** 38 inches high is standard  
Options: 33 and 43 inch high compartments are available as a special order.

**Rear Wheel:** Dual

**Color:** White

**Storage Compartments:** Aluminum diamond plate on top  
See page 31 for tool box configuration options

**Optional Top Rack:** Powder coated over the cab contour material rack

Style	Orientation	Tops
VO	Vertical	Open
HO	Horizontal	Open
V	Vertical	Closed
H	Horizontal	Closed

## SBD-98 Most Common Dimensions (SBD-98-96-51-38-VO)

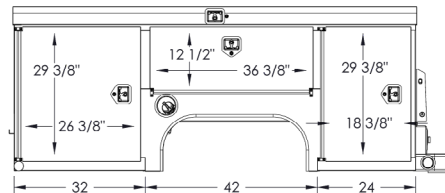
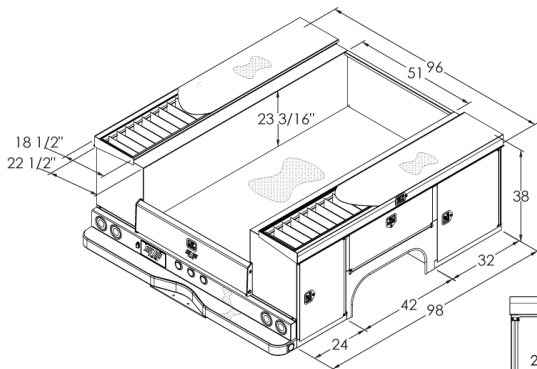

# SIGNATURE SERVICE Bodies - DUAL



**SBD-108 Most Common Dimensions (SBD-108-94-49-38-VO)**

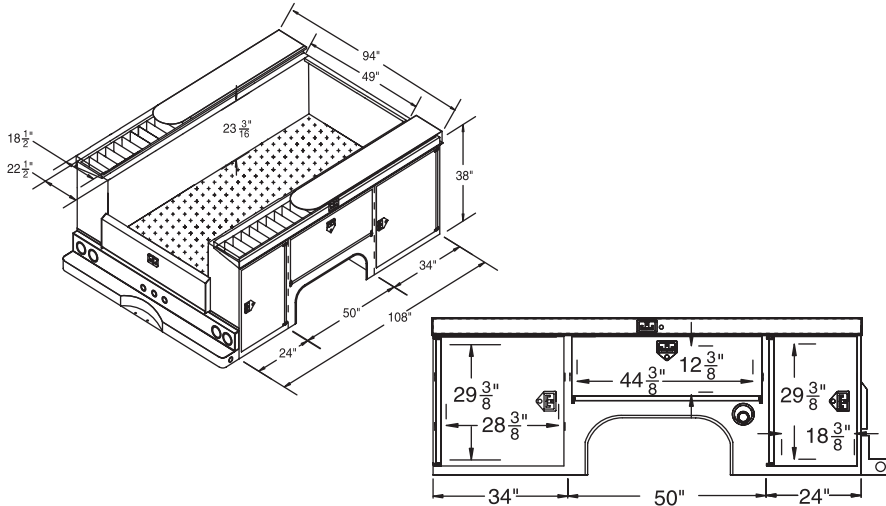

**SBD-132 Most Common Dimensions (SBD-132-94-49-38-VO)**

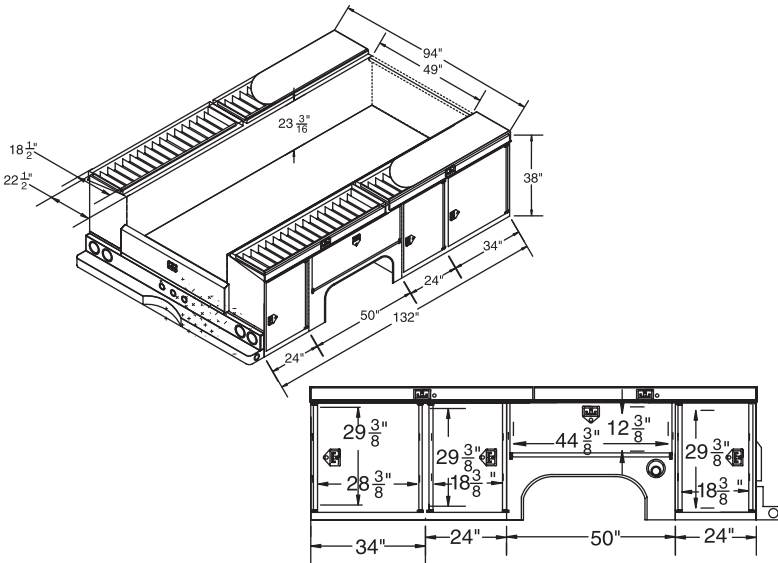

**SBD-156 Most Common Dimensions (SBD-156-94-49-38-VO)**

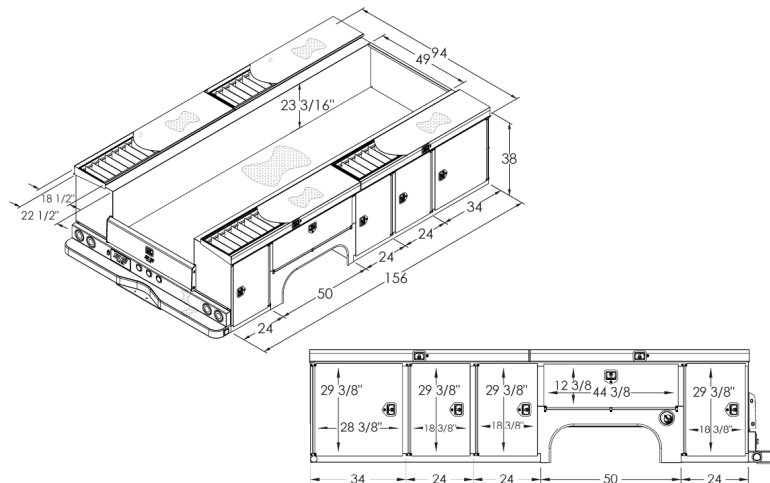

# SIGNATURE SERVICE Body Insert



Photos may contain optional equipment - verify your specifications when you order.

## Service Body Custom Dump Insert 2 Cubic Yard Capacity

### Body Dimensions:

**SB-98-79-49-38**

Length = 99.5 inches

56 CA

**SB-108-79-49-38**

Length=109.5 inches

60 CA

### Construction:

- 44" Wide Inside x 21" Sides x 22" Tail Gate x 21" Bulkhead
- 12 Ga. Steel Throughout
- 21" Bulkhead
- 22" Double Acting Tailgate with formed brace
- 3 Flange Top Rail
- Beveled Floor Corners at sides
- 4" channel crossmembers
- 5" Long Sills
- Pinned Tailgate Locks

### Color:

- White is standard

### Hoist:

- Scelzi CS412T-11 electronic over hydraulic single acting hoist 4.1 ton capacity
- Full steel sub-frame integrated into service body understructure
- Double acting, Power Up/Down
- LED Body Raised Warning Light

Style	Orientation	Tops
VO	Vertical	Open
V	Vertical	Closed



Dimensions for  
SB-98-79-49-38-VO  
2 CUBIC YARD DUMP INSERT

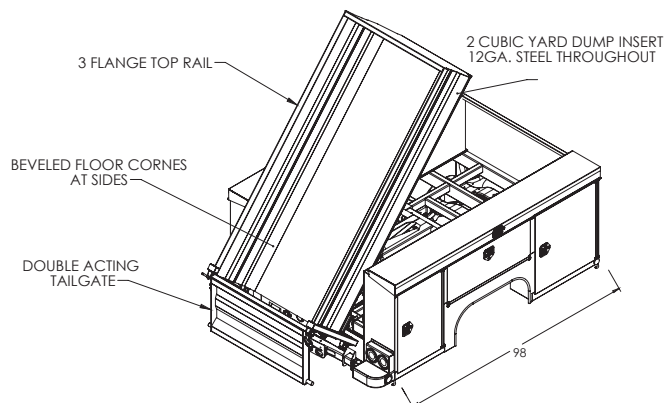
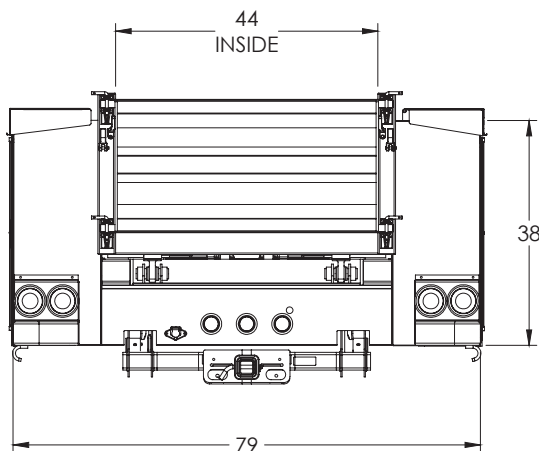

Dimensions shown represent 38" tall body with 22-1/2" wide compartments. Optional 20" wide compartments available.

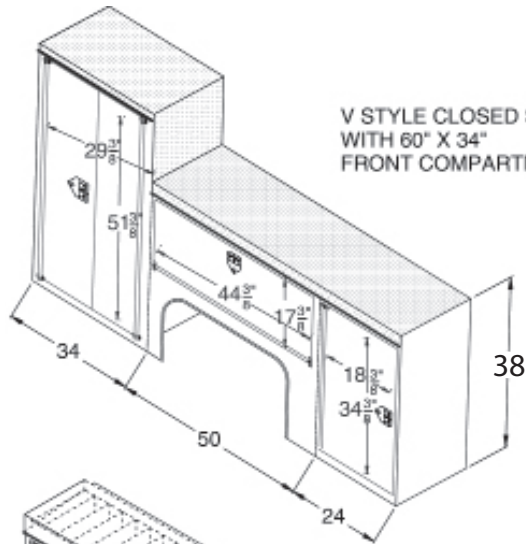

V STYLE CLOSED STYLE WITH 60" X 34" FRONT COMPARTMENT

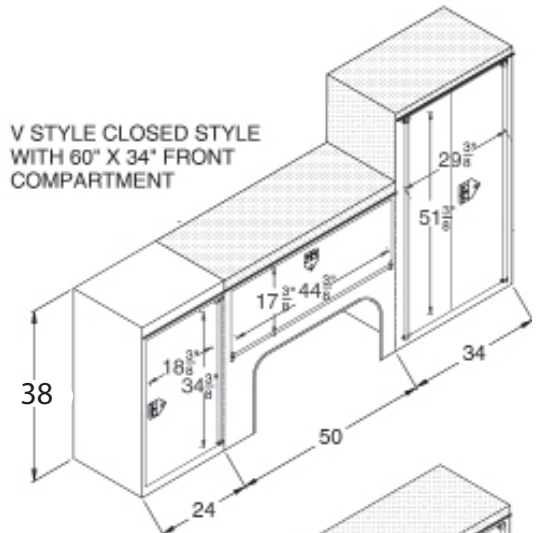

V STYLE CLOSED STYLE WITH 60" X 34" FRONT COMPARTMENT

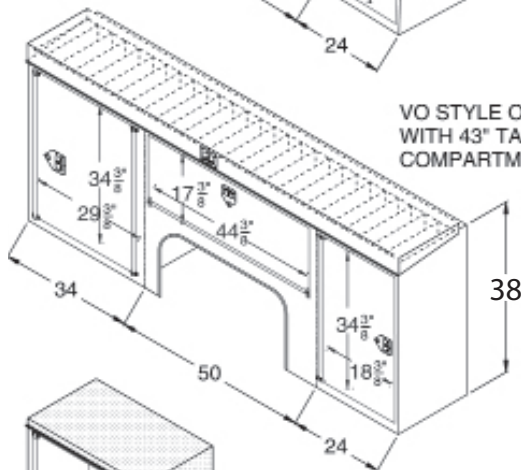

VO STYLE OPEN TOP WITH 43" TALL COMPARTMENT

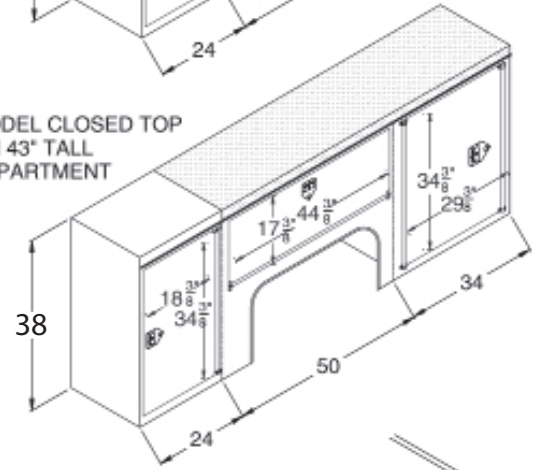

V MODEL CLOSED TOP WITH 43" TALL COMPARTMENT

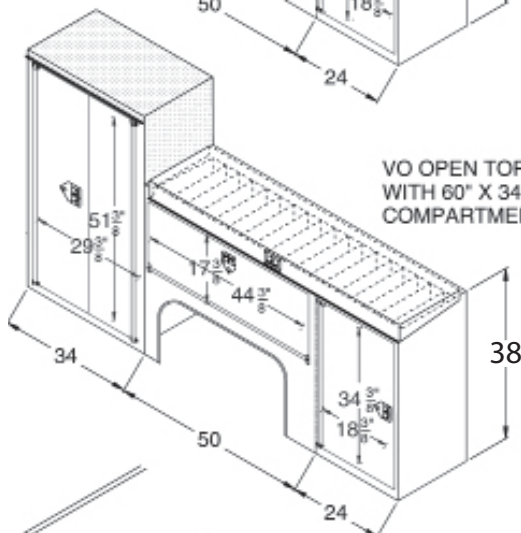

VO OPEN TOP STYLE WITH 60" X 34" TALL COMPARTMENT

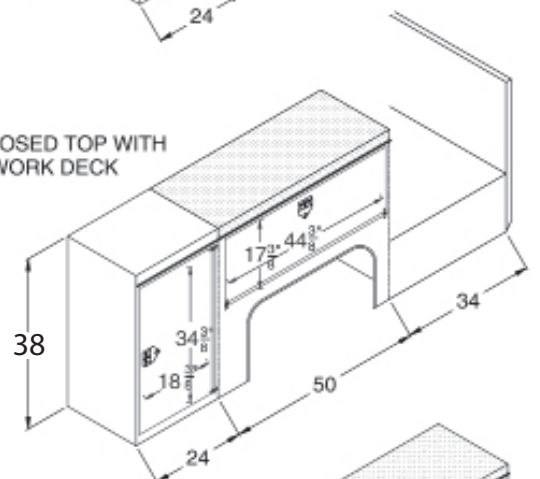

V CLOSED TOP WITH 34" WORK DECK

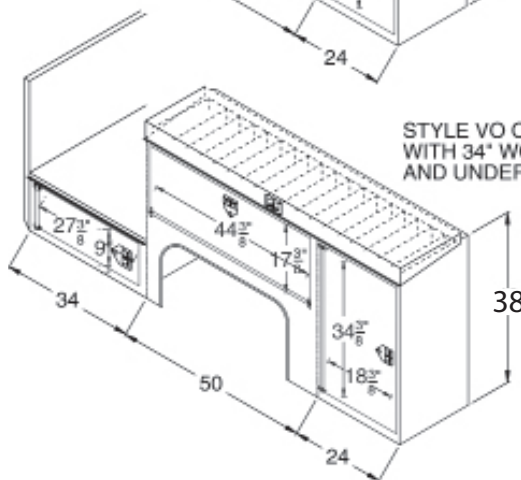

STYLE VO OPEN TOP WITH 34" WORK DECK AND UNDER BODY BOX

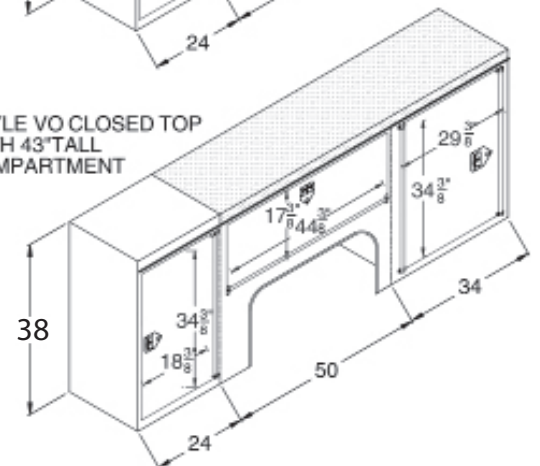

STYLE VO CLOSED TOP WITH 43" TALL COMPARTMENT

# Crane and Signature Service Body Configuration Options



Dimensions shown represent 38" tall body with 22-1/2" wide compartments. Optional 20" wide compartments available.

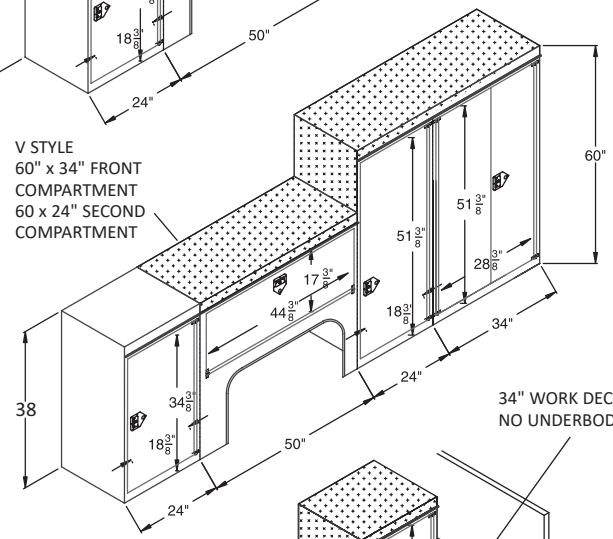
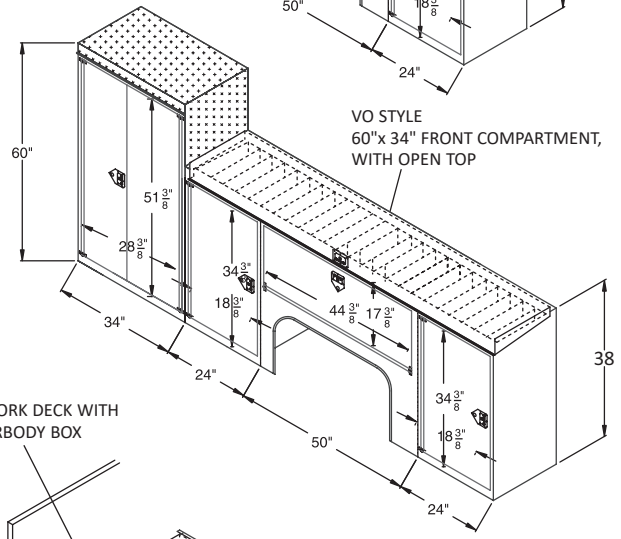
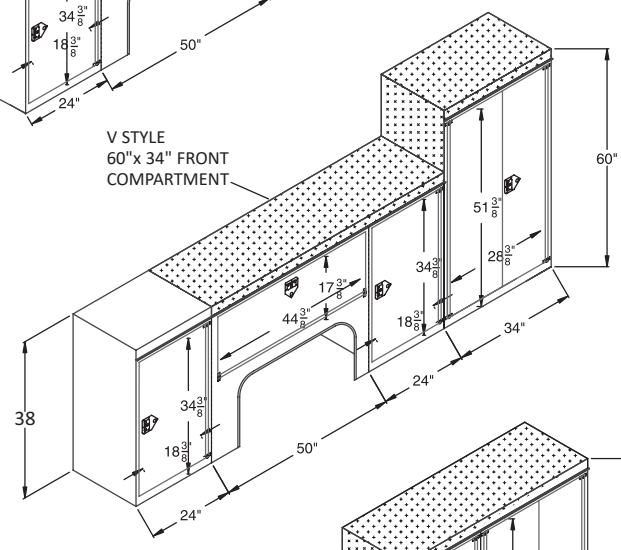
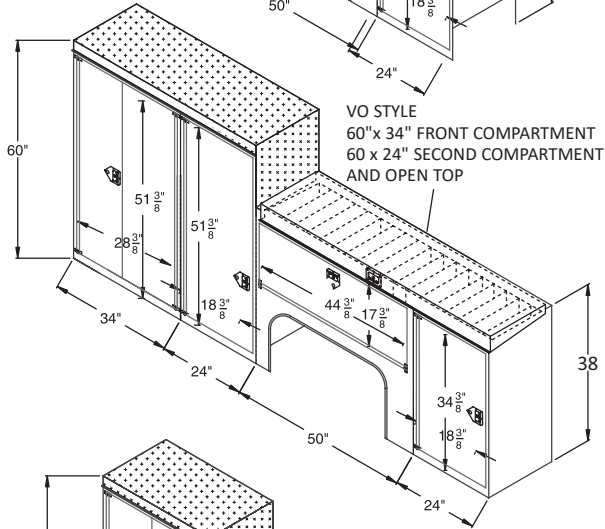
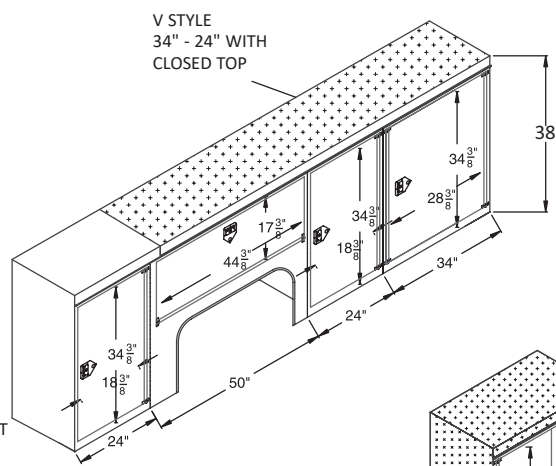
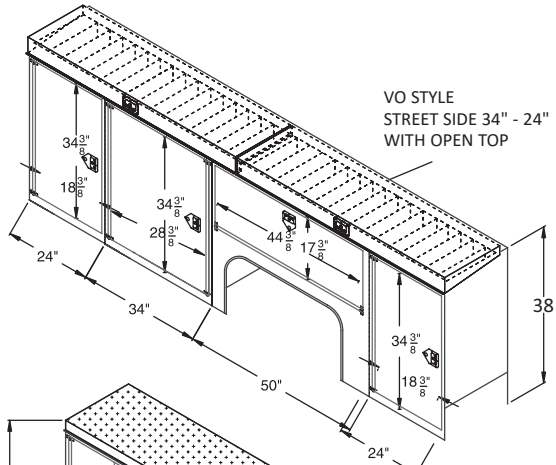

34" WORK DECK WITH UNDERBODY BOX

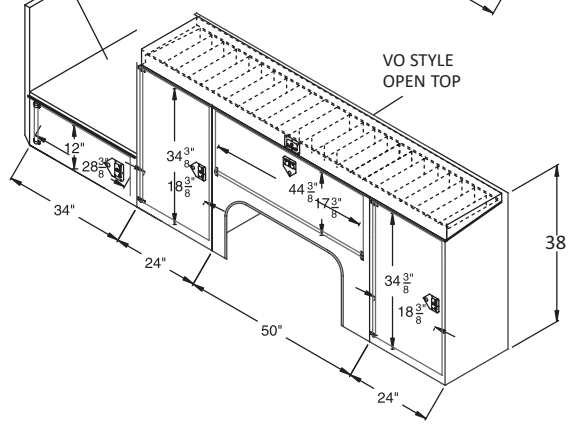

34" WORK DECK WITH NO UNDERBODY BOX

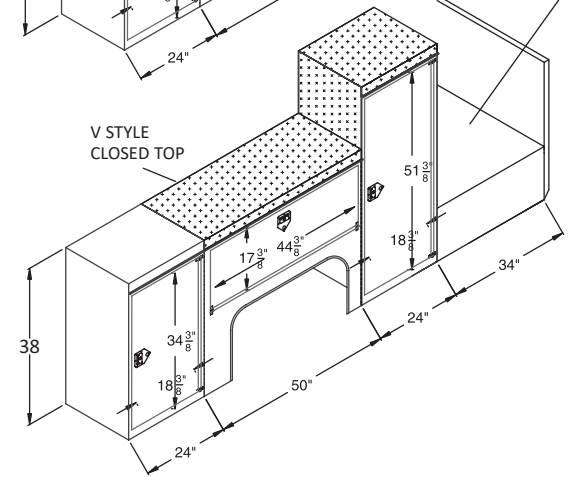



# Crane and Signature Service Body Configuration Options



Dimensions shown represent 43" tall body with 22-1/2" wide compartments. Optional 20" wide compartments available.

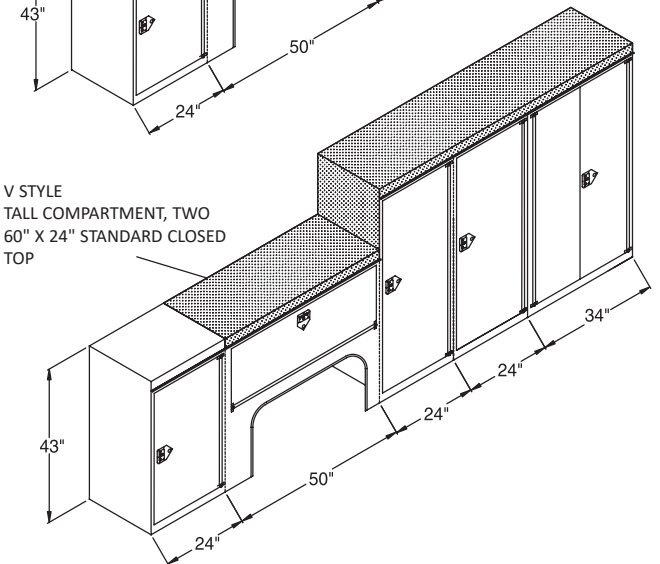
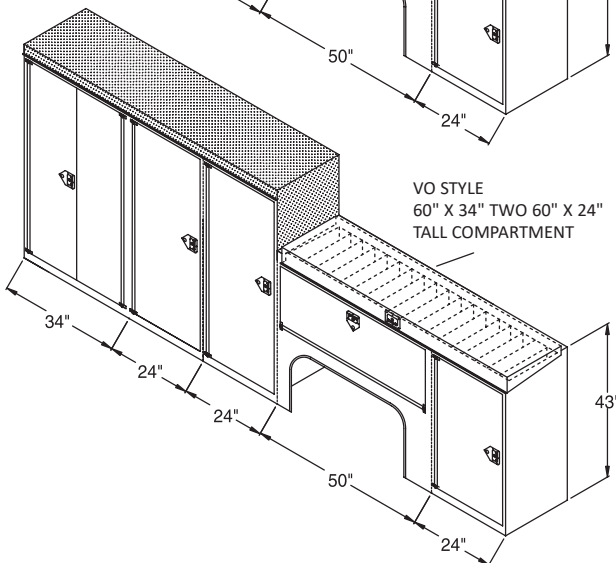
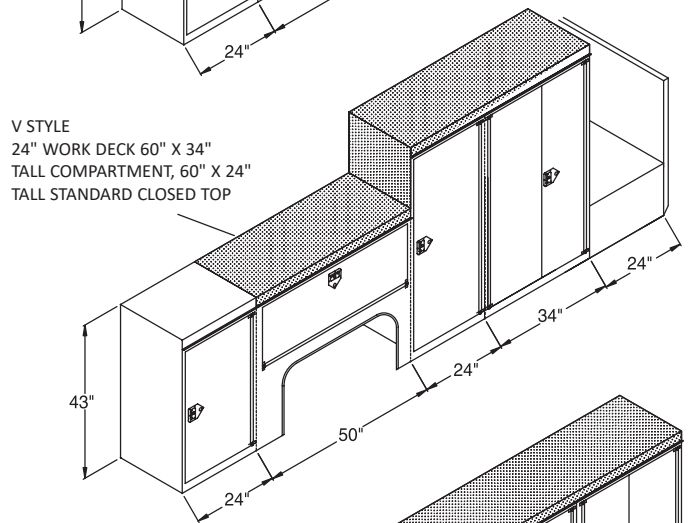
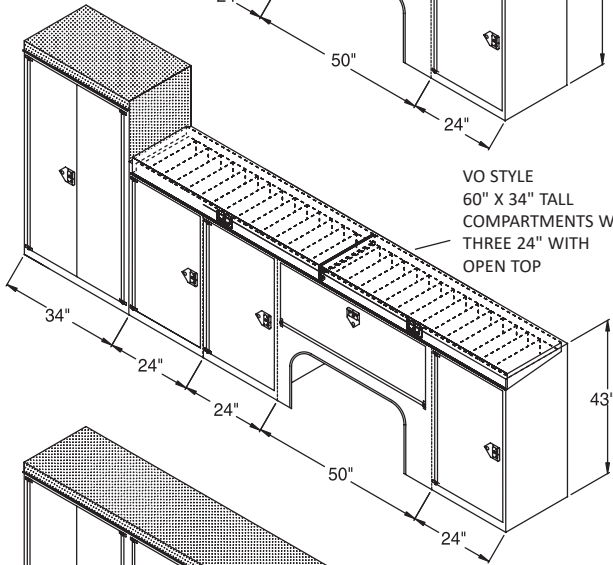
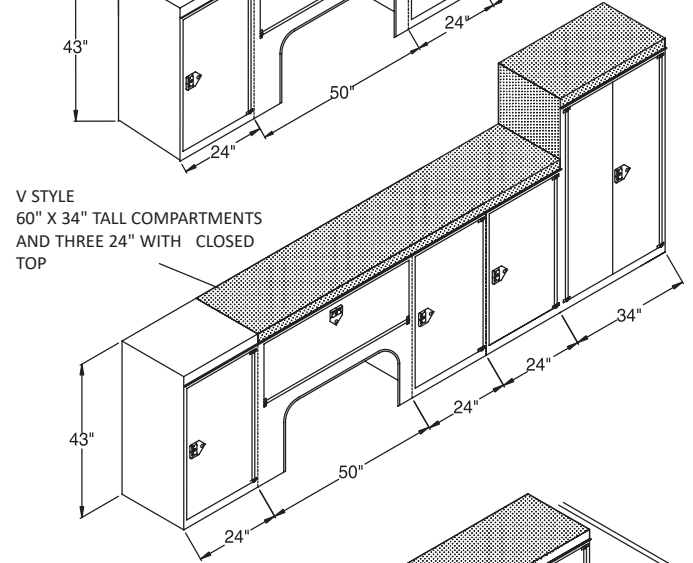
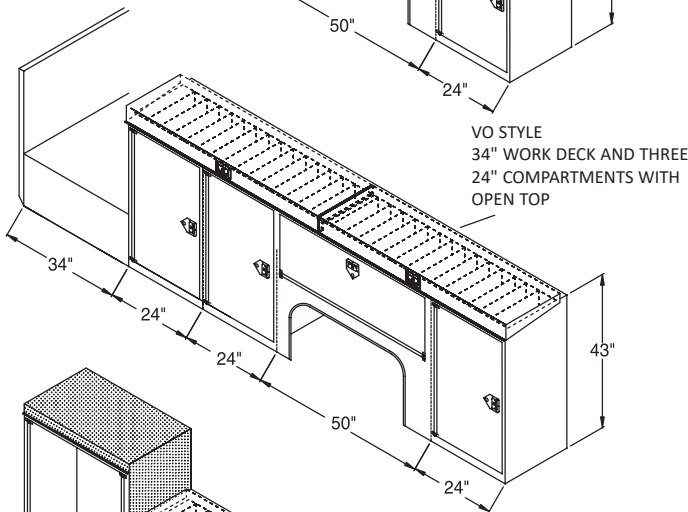
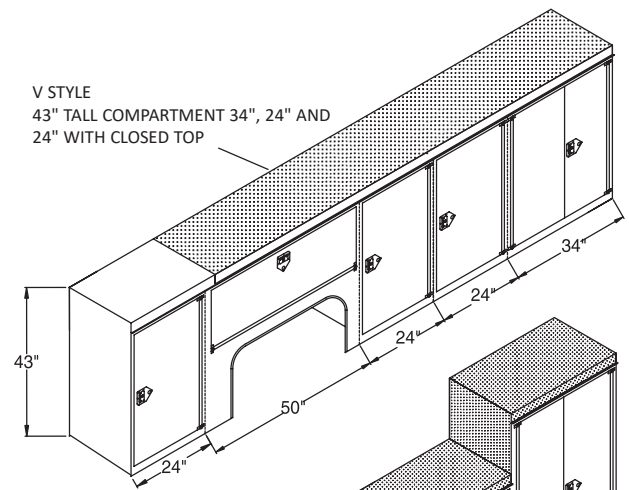
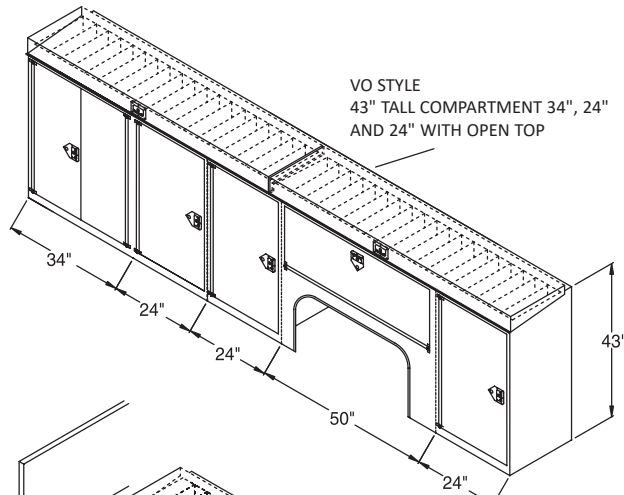



Photos may contain optional equipment - verify your specifications when you order.

## Super Structures for 8600 GVW\* and Higher Standard Specifications

GVW \* is Gross Vehicle Weight Rating, also known as Gross Vehicle Mass (GVM). This is the maximum operating weight of a vehicle chassis as specified by the manufacturer.

- Body Dimensions:**
- Lengths available in 98, 108, 132 and 156 inches only. Can be ordered with tapered sides.
  - Scelzi 6" recessed rear bumper and standard service body compartment options (see pages 31-33)  
Compartment height options are shown below.

- Window Options:**
- 1 front window 12" high X 28" wide.
  - Windows in rear doors 18" X 12" wide

- Color:**
- White or black

Body Height	SUPER STRUCTURE HEIGHT		
	24 inches	36 inches	48 inches
33"	42-3/16"	54-3/16"	66-3/16"
38"	47-3/16"	59-3/16"	71-3/16"
43"	52-3/16"	64-3/16"	76-3/16"

Dimensions are measured from the floor to the inside structure

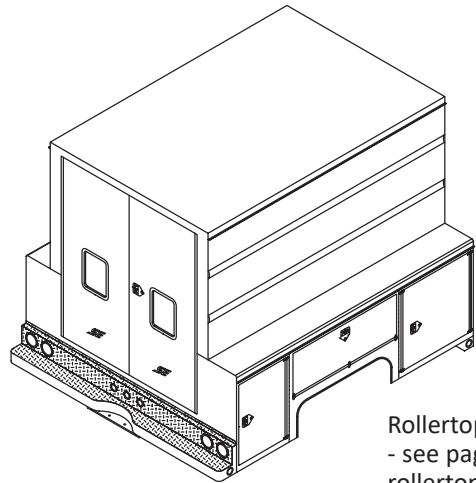

Standard Width Super Structure (SWSS)

Rollertops are optional - see page 56 for more rollertop options on Service Bodies

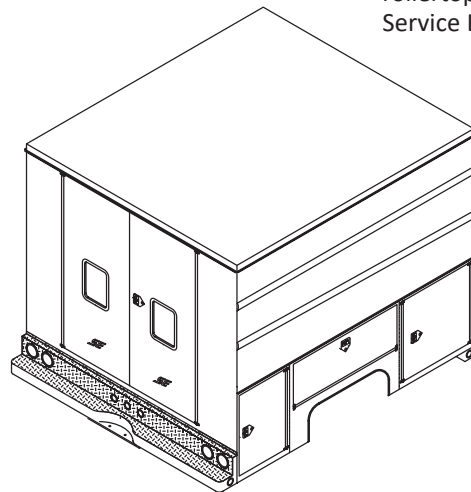

Full Width Super Structure (FWSS)





Photos may contain optional equipment - verify your specifications when you order.

## WCB-8000

## 132" Long

## Standard Specifications

Western Crane Body packages are available

**Body Dimensions:** • 132 inches Long x 96 inches wide, with capacity for 5,000-8000 lb crane.

**Color:** • White

**Storage Compartments:** • Compartment height is 43"

- Options:**
- 60" Tall Oxy-Acetylene Front Compartment (shown in photos above)
  - 24" or 34" Compartment 60" High with 3 Standard Adjustable Shelves
  - 18" to 24" Rear Work Deck – Set up for Outriggers with or without Access Doors
  - Rear Work Deck with Through Compartment
  - "Top 5" Only"
  - Work Deck with "V" Groove
  - V-Notch Bumper

Style	Orientation	Tops
VO*	Vertical	Open
V	Vertical	Closed
* Only available on non-crane side		

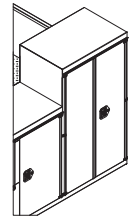

CRANE BODIES ARE ALSO AVAILABLE WITH OPTIONAL 60" TALL FRONT COMPARTMENTS



Dimensions shown are for  
WCB-132-96-56-43-V

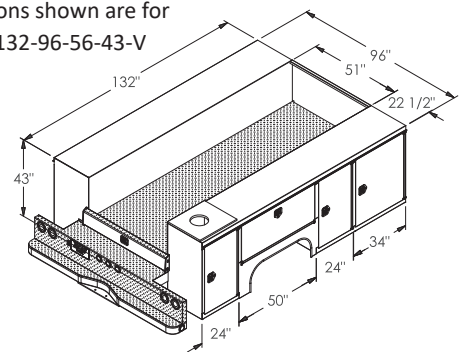

CRANE BODY UNDERSTRUCTURE AND REINFORCEMENT

3 X 5 X .250" WALL CROSS SUPPORTS

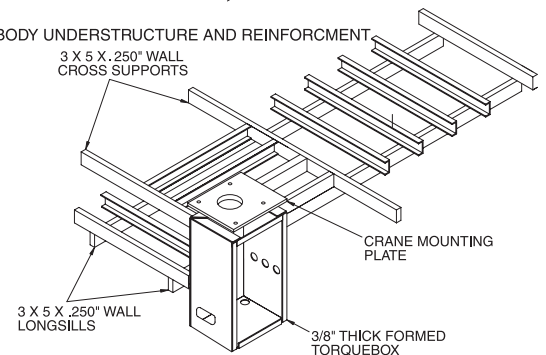

OR BUMPER  
WITH TYPE-D NOTCH

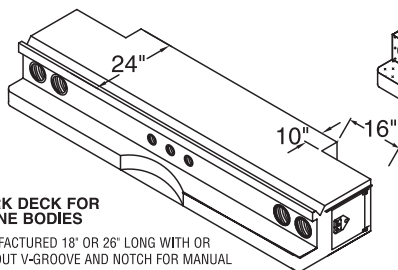

WORK DECK FOR  
CRANE BODIES

MANUFACTURED 18" OR 26" LONG WITH OR WITHOUT V-GROOVE AND NOTCH FOR MANUAL OR HYDRAULIC OUTRIGGERS



Photos may contain optional equipment - verify your specifications when you order.

**SBD-108-94-49      108" Long      60 CA      Standard Specifications**

- Body Dimensions:**
- 108 inches Long x 94 inches wide. Compartment height is 33 inches.
  - Custom Order Only: 132 inch Long body, as shown in photo above.

- Rear Wheel:**
- Dual

- Color:**
- White

- Storage Compartments:**
- Tapered Front Compartments and Smooth Steel Floor with a 5" Drop
  - Oxygen Bottle Holders in Transverse Compartment - Driverside
  - Acetylene Bottle Holders in Upright Position in Front Compartment - Driverside
  - Hose Holder in Front Compartment - Driverside
  - Oxygen and Acetylene Hose Reel with Louver in Lower Bottom of Front Compartment - Driverside
  - Adjustable Shelves in Front Compartment - Curbside
  - Horizontal Compartment with Dividers
  - Rear Work Deck with Access Doors and "V" Groove
  - Perforated Rear Step Bumper
  - Class 5 Receiver Hitch Without Insert
  - Trailer Plug 7/4 Way OEM Socket

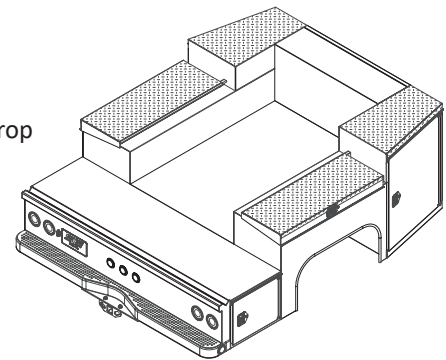

Dimensions shown are for SBD-108-94-49-33-V

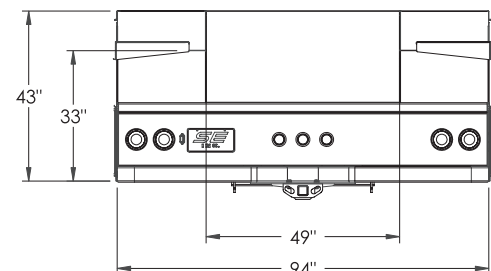
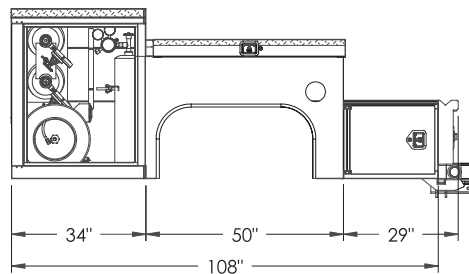

Optional Polyurea lining

All drawings reflect dimensions for the most popular applications.



Photos may contain optional equipment - verify your specifications when you order.

## Hoist Specifications - Smaller Dump Sizes

The Scelzi line of durable, single stage scissor hoists:

- Range in capacity from 11.2 to 22.5 ton
- Fit bodies from 8 to 20 feet long
- Black powder-coated in a durable, rust-resistant finish
- In-Cab Dash-mounted LED "Hoist Up" Safety Light
- Internally/externally accessed Push Button Hoist Up-Down Controller
- Dual, Manual-control Hoist Secure Locking Arms
- Power Take Off (PTO) for most models
- Scelzi CS515T and CS615T-11 are electric/hydraulic



Dash-mounted LED "Body Up" Safety Light and Push Button Hoist Up-Down Controller

### Scelzi Hoists Standard Sizes

Body	Model	Tons
12' Chipper	CS615T-11	11.2
14' Chipper	CS620HD	11.5
16' Chipper	CS628	15.1
2-3 Yd Dump	CS615T-11	12.6
3-4 Yd Dump	CS615T-11	11.2
5-7 Yd Dump	CS820DA	22.5
6-8 Yd Dump	CS6620	22.9
7-9 Yd Dump	CS6620	22.9
10-12 Yd Dump	820DA	22.5
8'6" Landscaper	CS615T-11	12.6
10' Landscaper	CS615T-11	11.2
12' Landscaper	CS615T-11	11.2
14' Landscaper	CS615T-11	9.2

Actual hoist specifications may vary



Dual manual-control Hoist Secure Locking Arms





Photos may contain optional equipment - verify your specifications when you order.

## 3-4 Cubic Yards    11.6 Ft. Long    84 CA    Standard Specifications

- Capacity:**
- Recommended: 14,000 - 19,000 GVW Approx. 2,250 lbs.
  - Recommended: 550, 5500 or lower
- Body Dimensions:**
- Traditional rectangular body with cross-members
  - 11'6" Long x 86" Wide Inside x 13" Sides x 20" Tail Gate x 32" Bulkhead
  - DBS 11-6 Dump body with fold down sides
  - 10 Gauge High-Tensile Throughout
  - 3" Cross Bars on 15" Centers x 5" Channel Longs
  - 1/4 Size Cab Shield
  - Deluxe LED Light Package with Oval Stop and Turn Lights
  - Mud flaps and brackets
  - Semi automatic pull tarp, black mesh
- Color**
- Black or white, Contact Sales for Custom Color
- Hoist:**
- Scelzi CS615T-11 (Class 40)
  - 11.2 ton capacity with 12" overhang, full steel sub-frame
  - Power up and power down with LED raised up warning light
  - LED body raised warning light, inside cab control
  - See pg 37 for more hoist information
- Options:**
- 6" x 3/16" spreader apron
  - Center ditch gate, sliding type
  - 3/16" floor in lieu of 10 gauge
  - LED lighting
  - Non-fold down sides

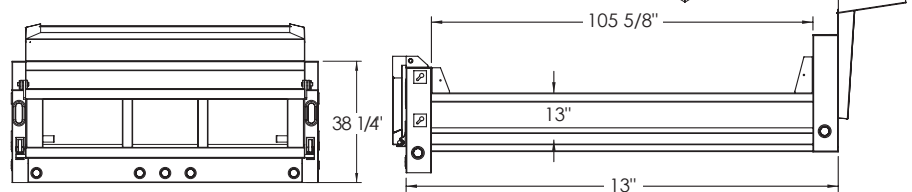
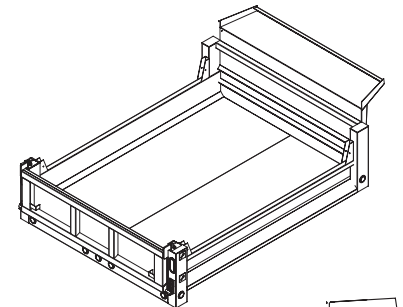
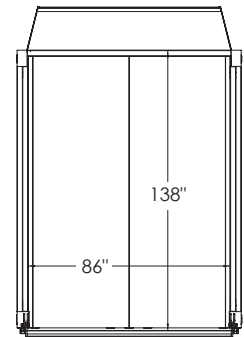
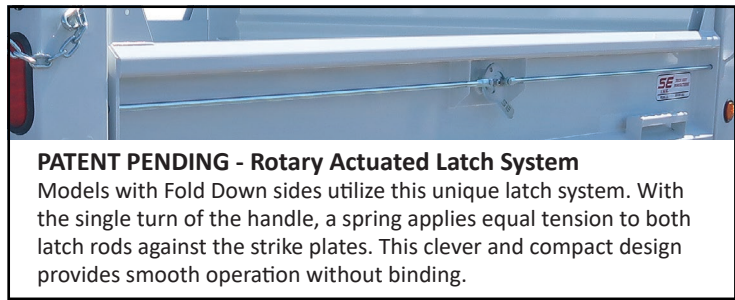

NOTE: 13" DIMENSION IS FROM FLOOR TO TOP OF SIDE RAIL





Photos may contain optional equipment - verify your specifications when you order.

## 5-7 Cubic Yards      10 Ft. Long      Standard Specifications

**Capacity:**      • Recommended: 26,000 -33,000 GVW      Approx 3,400 lbs.

**Body Dimensions:**

- Traditional rectangular body with cross-members
- 10' Long x 86" Wide Inside x 24" Sides x 32" Tail Gate x 36-40" Bulkhead
- 10 Gauge High-Tensile Steel Sides and Ends
- 3/16" High-Tensile Steel Floor with Beveled Side Corners
- Sloped Running Boards
- 6" Channel Longs x 3" Channel Cross Bars on 15" Centers
- Double Acting Tail Gate (Manual Trip Lever), 6-Panel
- 1/4 Cab Shield, Full Depth Rear Corner Post
- 4-Flange Boxed Top Rail, Double
- Wall Sides with Center Corrugation, Spreader Apron
- Deluxe LED Light Package with Oval Stop and Turn Lights in Rear Corner Post,
- Recessed Side Clearance Lights, and Set of Mud Flaps

**Color:**      • Black or White

**Hoist:**

- Scelzi 820DA with sub-frame (Class 60)
- 22.5 ton capacity with 12" overhang
- Power up and power down with LED raised up warning light
- LED body raised warning light, inside cab control
- See pg 37 for more hoist information

**Options:**

- Ditch Gate in Tailgate
- Semi automatic pull tarp, black mesh
- 3/16" High-Tensile Tailgate
- Air Operated Tailgate Locks
- Air Shift PTO or Hot Shift PTO - for Allison Transmission
- 580 Premier Pintle Hitch or Plug
- Pull Trap, and Toolbox

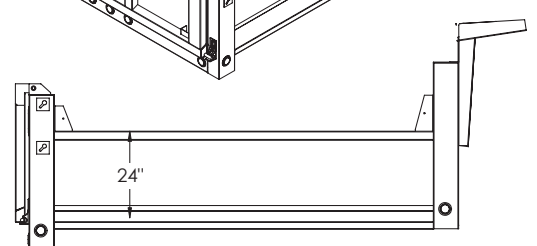
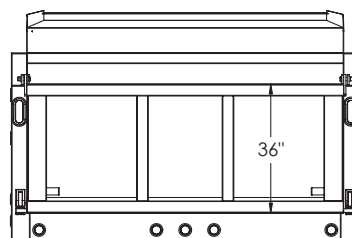
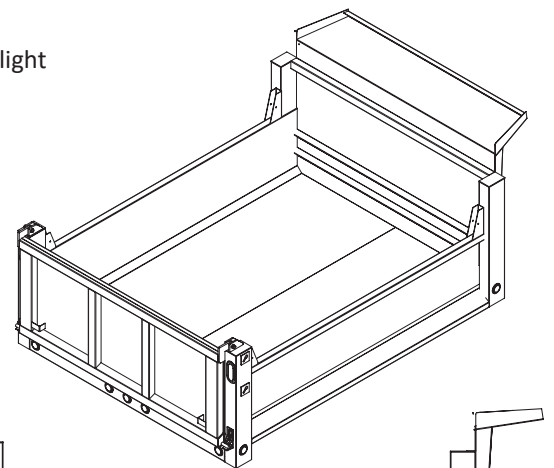
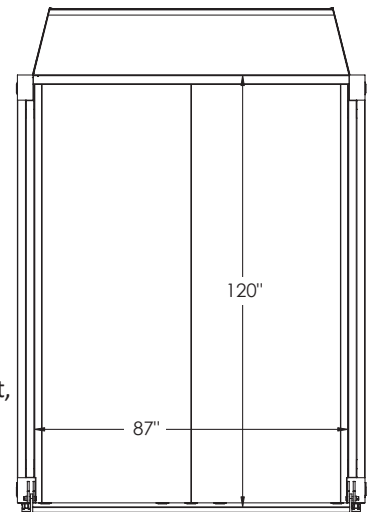



Photos may contain optional equipment - verify your specifications when you order.

**10-12 Cubic Yards**

**14 Ft. Long**

**Standard Specifications**

**Capacity:**

- Recommended: 33,000 GVW

**Body Dimensions:**

- Traditional rectangular body with cross-members
- 10 GA. High-Tensile Steel Throughout
- 3" Channel Crossbars on 15" Centers
- Headboard with Corrugations 10" Higher Than Sides
- Manual Tailgate Lever or Air Cylinder Set-Up (Air Cylinder not Included)
- 5", 6", or 7" Longsills
- Tailgate 6" Higher Than Sides
- Beveled Floor Corners
- Full Depth Rear Corner Posts
- Two-Panel Tailgate
- Boxed Top Rails and Horizontal Side Braces

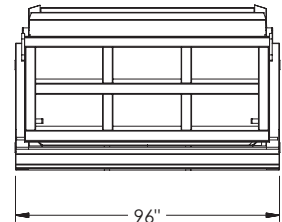
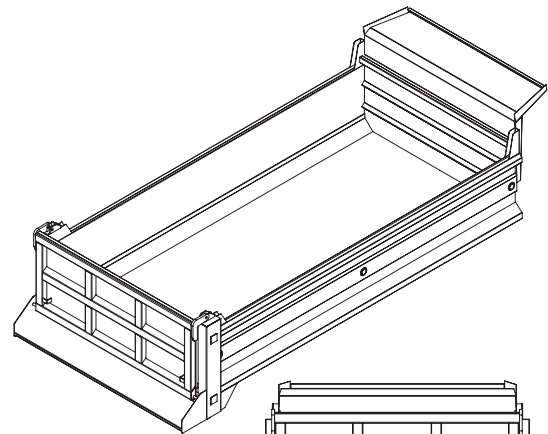

**Color:**

- Black or White

**Hoist:**

- Scelzi C63120T
- 22.5 ton capacity with 12" overhang
- Power up and power down with LED raised up warning light
- See pg 37 for hoist details

**Options:**

- Air Tailgate Control
- Air Dump Control
- 3/16" Spreader Apron
- Ditch Gates
- Oval Stop and Turn Lights
- Front Corner Post
- Nested Crossbars
- Double Wall Sides with Center Horizontal Brace Length of Body
- Concave sides
- Hoist Stabilizer
- Guards in End Post for Turn Signal Lights
- Hydraulic Wet Line for Pop Trailer
- Electrically Activated PTO for Manual Transmission
- Air Pintle Hitch
- Semi automatic pull tarp, black mesh (as shown at right)

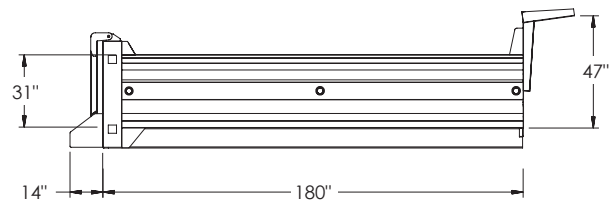





Photos may contain optional equipment - verify your specifications when you order.

## Semi-Elliptical Dump Bodies

## Various Lengths

## Standard Specifications

**Capacity:** • Varies from 6-18 cubic yards in lengths from 10 to 19 feet long

**Body Dimensions:**

- Semi-elliptical curved body design
- 4 x 4 x 1/4 Tubing Top Rail Diamond Up Inside Vertical Stiffner
- 10 Gauge High-Tensile Fenders Starting Approx. 30" from Front
- Fenders are Full Boxes Closed Bottom Side, 100% Welded
- All Heavy Duty Hardware Top & Bottom on Tailgate
- 3 Panel Tailgate or 6 Panel Tailgate
- Air Operated Lower Tailgate Locks
- 1/4 Size Cab Shield or Wing Type
- 8" x 3/16" Spreader Apron
- Deluxe Light Kit Oval Stop & Turn

**Color:** • Black or White

**Hoist:**

- Model varies by capacity
- Power up and power down
- LED raised up warning light

**Options:**

- Air Lift Tailgate Cyl. Inside Rear Post (No Door)
- Doors on Rear Corner Post for Air Cyl Access
- Ditch Gate Center
- Trap (Manual or Electric)
- Air Hitch 370 Premier and Electric Plug
- 2 – 22.5 x 8.25 Alcor Uni-Mt F/R Polished 10 Hole Wheels
- 2 – 255/70 R22.5 Sumitomo S+727 16 Ply Tires
- Reverse Mounting Model for Clearance on Tanks ECT

**Custom Dump Bodies:** • Other Custom Dump Bodies Available as a Special Order  
- Please Contact Us

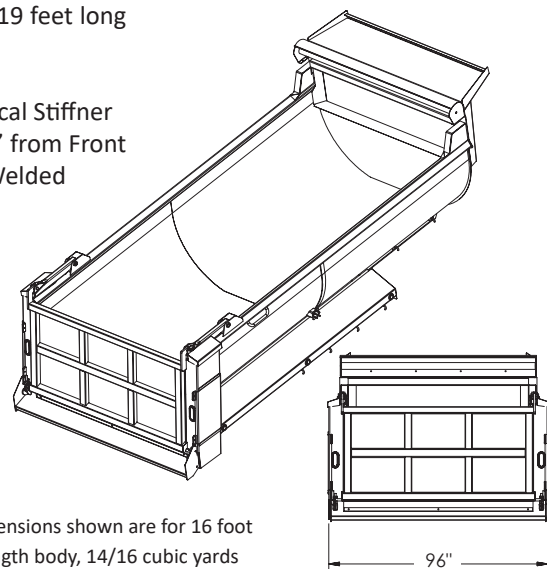

Dimensions shown are for 16 foot length body, 14/16 cubic yards

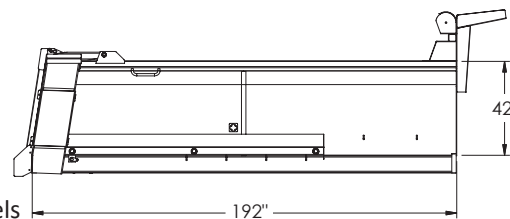



Photos may contain optional equipment - verify your specifications when you order.

**12 Foot Chipper and Hoist**

**84 CA**

**11.2 Ton Hoist**



Photos may contain optional equipment - verify your specifications when you order.

**14 Foot Chipper and Hoist**

**120 CA**

**15.2 Ton Hoist**

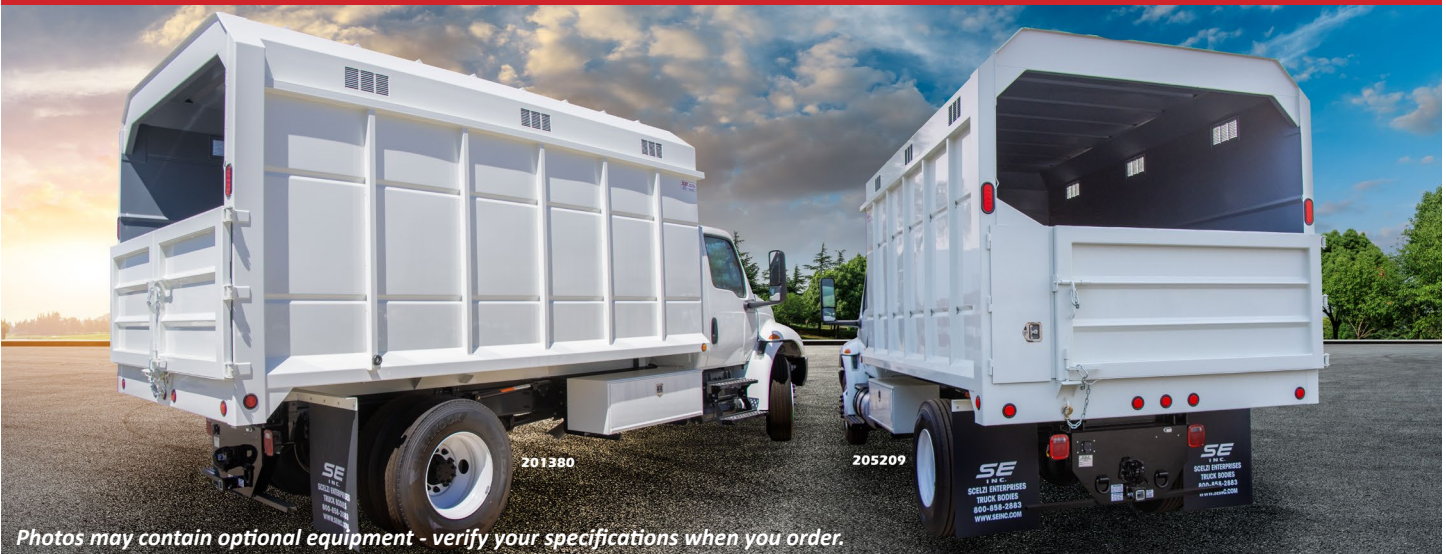

Photos may contain optional equipment - verify your specifications when you order.

**16 Foot Chipper and Hoist**

**138 CA**

**17.6 Ton Hoist**



*Optional lighting and toolbox configurations are available*



## Chipper and Hoist

## Standard Specifications

### Body Dimensions Available:

12 ft. Long x 88 Inches Wide  
 14 ft. Long x 88 Inches Wide  
 16 ft. Long x 88 Inches Wide

84 CA  
 120 CA  
 138 CA

Body Length	12 ft	14 ft	16 ft
Recommended GVW	19,000	26,000 - 33,000	26,000 - 33,000
Hoist Capacity	11.2 tons	15.2 tons	17.6 tons
Cab-to-Axle inch length (CA)	84 CA	120 CA	138 CA
Outer Body Width	88 inches	88 inches	88 inches
Inner Body Height	78 inches	84 inches	84 inches
Body Details:	10 gauge High Tensile floor with beveled side corners and front		
	3 inch channel cross bars on 15 inch centers		
	5 inch channel longs	7 inch channel longs	7 inch channel longs
	12 gauge front bulkhead with 3 corrugations and tube stiffeners 12 gauge sides and 2 corrugations and vertical posts		
	30 inch rear swing-out double doors with door latch	36 inch rear swing double doors with door latch	36 inch rear swing double doors with door latch
Hoist:	Scelzi CS615T-11 Electric over hydraulic Underbody Hoist, Class 40* <ul style="list-style-type: none"> <li>11.2 ton capacity with 18" overhang, full steel subframe</li> <li>Double acting hoist with Power Up and Power Down PTO with direct mount pump</li> <li>LED raised warning light</li> <li>Inside Cab control</li> </ul>	Scelzi CS 6615 Direct Mount Underbody Hoist, Class 50* <ul style="list-style-type: none"> <li>15.2 ton capacity with 18" overhang</li> <li>2" hardwood cushion on truck chassis</li> <li>Hydraulic tank</li> <li>Double acting hoist with Power Up and Power Down PTO with direct mount pump</li> <li>LED raised warning light</li> <li>Inside Cab control</li> </ul>	Scelzi CS6620 Direct Mount Underbody Hoist, Class 50* <ul style="list-style-type: none"> <li>17.6 ton capacity with 23" overhang</li> <li>2" hardwood cushion on truck chassis</li> <li>Hydraulic tank</li> <li>Double acting hoist with Power Up and Power Down PTO with direct mount pump</li> <li>LED raised warning light</li> <li>Inside Cab control</li> </ul>

\*See page 37 for more hoist information



## Key Features and Options on Scelzi Water Trucks



Three square Manholes on 4000 gallon tanks

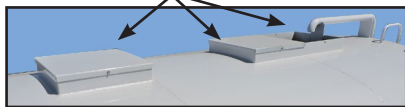

Cab control box

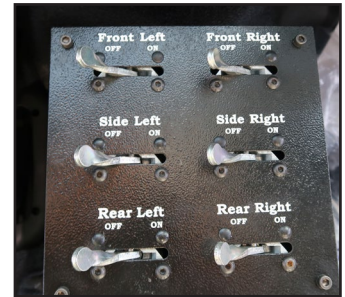

Two 24" x 24" Manholes



3/16" thick steel tank skins welded inside and out

2.5" Hydrant Fill Pipe

Optional Hose Reel

Driver and passenger-side Adjustable Spray Fittings

Front and Rear Spray Bars

Heavy Duty Steel Ladder



24" Stinger Storage with lockable lid

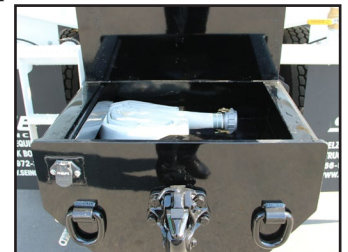

### Unique Scelzi Water Tank Features:

- A-Rubber Mounts between the long sill and chassis to minimize vibration
- B-Spring tank mounts to act as shock absorbers independent of the chassis



Optional LED Enhanced Light Kit



Optional 1/4" Thick Belly Steel Overlay



Photos may contain optional equipment - verify your specifications when you order.

## WT-2000

2,000 Gallons

## Standard Specifications

### Standard

- Features:**
- Chelsea Air Shift PTO
  - 4" x 3" Berkeley water pump (750 GPM)
  - Spicer PTO Driveline
  - 4" x 4" Water Manifold
  - 3" Standard Air Valves
  - 3" Slip on splash spray heads for front
  - 3" x 53" Front spray bar with mounting brackets
  - 3" Slip on splash spray heads for rear
  - 3" x 53" Rear spray bar with mounting brackets
  - 3" Adjustable driver side spray with VIC clamps
  - 3" Adjustable passenger side spray with VIC clamps
  - One control box inside cab with (6) air switches and Air control for PTO
  - 1-1/2" Gate valve at manifold
  - 3/4" Gate valve at manifold
  - 4" Water tank mounts with 3/4" bolts
  - One set of water tank fenders with hooks for hoses
  - OEM Tail Stop & turn rear lights
  - 2-1/2" Red marker lights seal beam
  - 2-1/2" Amber marker lights seal beam
  - 36" Rubber mud flaps
  - 24" Stinger at rear with lockable lid
  - 1/2" Sight gauge at rear

### Options:

- Hot shift PTO for Allison Transmission
- Upgrade to CLA – Val Air Valves
- 1/4" Thick overlay "Belly" at lower level of standard 3/16" thick tank, which significantly slows "rot-out" of bottom of tank
- 6" Diameter gravity water tank dump valve at rear bottom of tank with "Fan Nozzle".

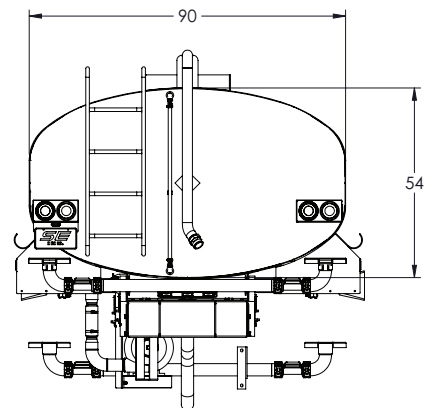
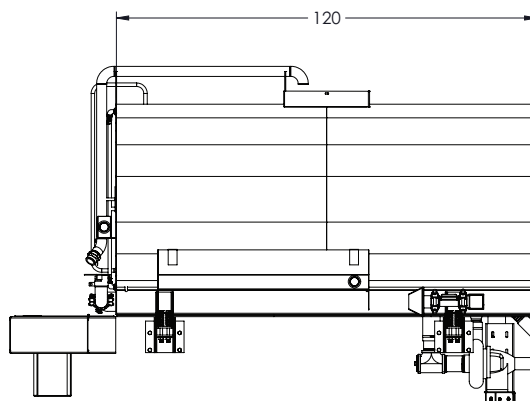
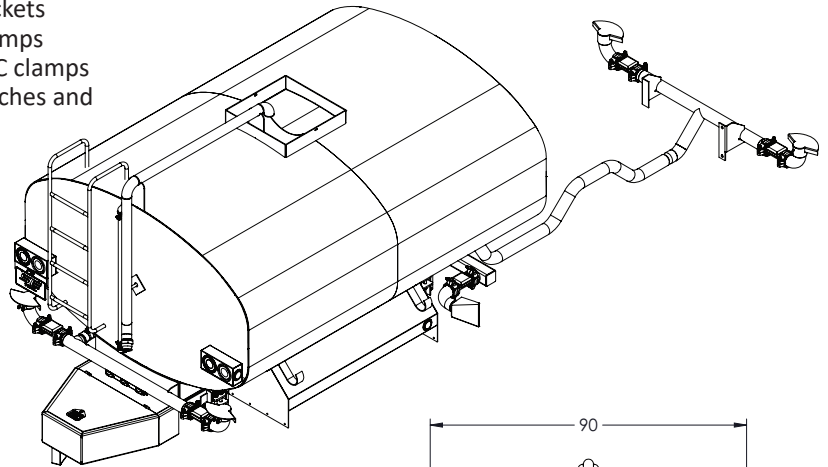



Photos may contain optional equipment - verify your specifications when you order.

**WT-2500**

**2,500 Gallons**

**Standard Specifications**

**Standard Features:**

- Chelsea Air Shift or Hot Shift PTO
- 4" x 3" Berkeley water pump (750 GPM)
- Spicer PTO Driveline
- 4" x 4" Water Manifold
- One set of water tank fenders with hooks for hoses
- 4" Water tank mounts with 3/4" bolts
- OEM tail stop & turn rear lights
- 3" Standard Air Valves
- 3" Slip on splash spray heads for front
- 3" x 53" Front spray bar with mounting brackets
- 3" Slip on splash spray heads for rear
- 3" x 53" Rear spray bar with mounting brackets
- 3" Adjustable driver side spray with VIC clamps
- 3" Adjustable passenger side spray with VIC clamps
- One control box inside cab with (6) air switches and Air control for PTO
- 1-1/2" Gate valve at manifold
- 3/4" Gate valve at manifold
- 2-1/2" Red marker lights seal beam
- 2-1/2" Amber market lights seal beam
- 36" Rubber mud flaps
- 24" Stinger at rear with lockable lid
- 1/2" Sight gauge at rear

**Options:**

- Hot shift PTO for Allison Transmission
- Upgrade to CLA – Val Air Valves
- 1/4" Thick overlay "Belly" at lower level of standard 3/16" thick tank which significantly slows "rot-out" of bottom of tank
- 6" Diameter gravity water tank dump valve at rear bottom of tank with "Fan Nozzle".

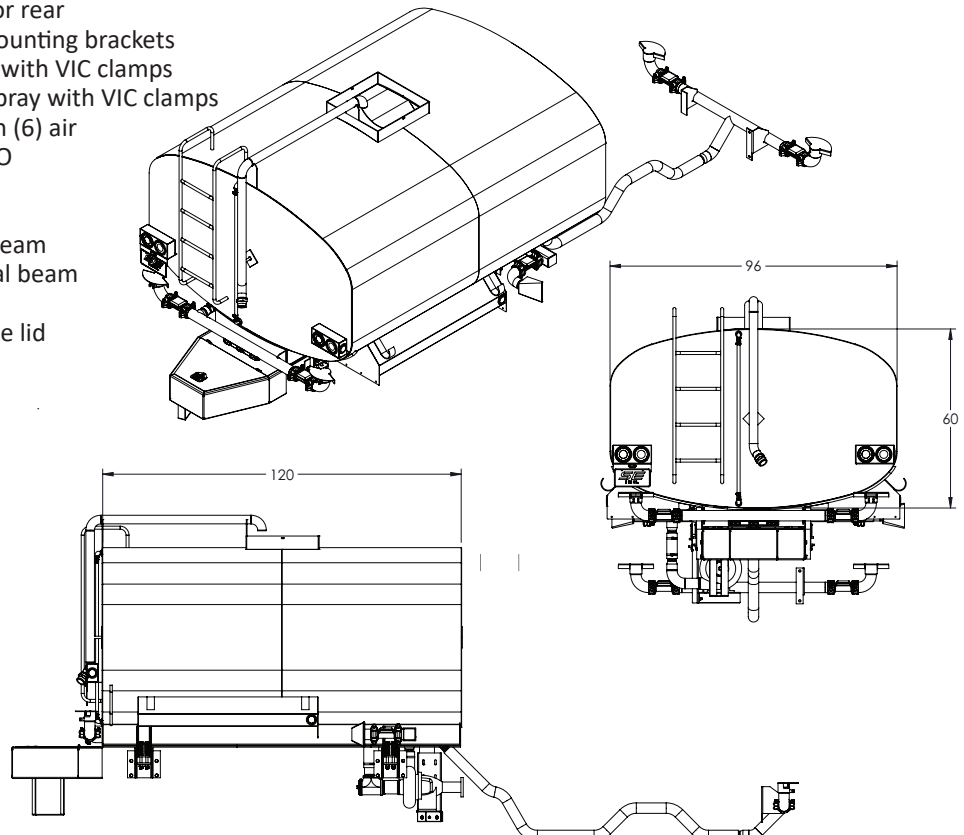



Photos may contain optional equipment - verify your specifications when you order.

## WT-4000

4,000 Gallons

## Standard Specifications

### Standard

- Features:**
- Chelsea Air Shift PTO for manual transmission
  - 4" x 3" Berkeley water pump, (750 GPM)
  - Spicer PTO Driveline
  - 4" x 4" Water Manifold
  - 3" Standard Air Valves
  - 3" Slip on splash spray heads for front
  - 3" x 53" Front spray bar with mounting brackets
  - 3" Slip on splash spray heads for rear
  - 3" x 53" Rear spray bar with mounting brackets
  - 3" Adjustable S/S spray with VIC clamps
  - 3" Adjustable C/S spray with VIC clamps
  - One control box inside cab with (6) air switches and Air control for PTO
  - OEM tail stop and turn rear lights
  - 2-1/2" Red marker lights seal beam
  - 2-1/2" Amber marker lights seal beam
  - 36" Rubber mud flaps
  - 24" Stinger at rear with lockable lid
  - 1/2" Sight gauge at rear
  - 1-1/2" Gate valve at manifold
  - 3/4" Gate valve at manifold
  - 4" Water tank mounts with 3/4" bolts
  - One set of water tank fenders with hooks for hoses

### Options:

- Hot shift PTO for Allison Transmission
- Upgrade to CLA – Val Air Valves
- 1/4" Thick overlay "Belly" at lower level of standard 3/16" thick tank, which significantly slows "rot-out" of bottom of tank
- 6" Diameter gravity water tank dump valve at rear bottom of tank with "Fan Nozzle".

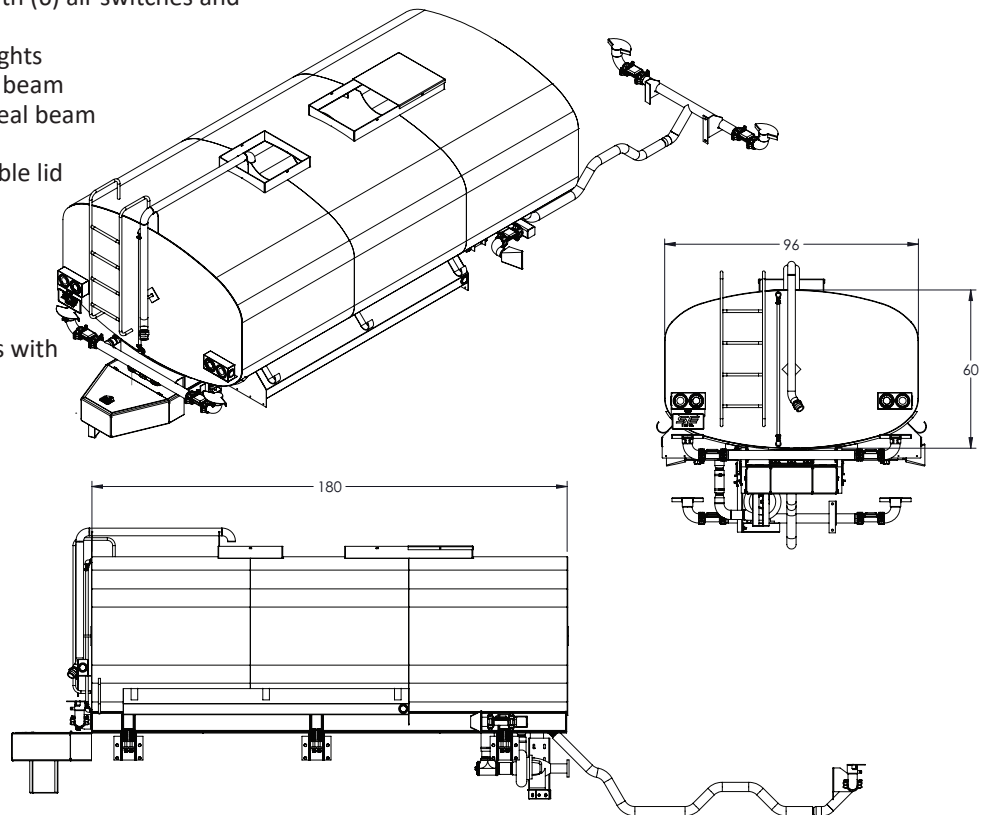



# SCELZI EQUIPMENT

## Truck Parts and Accessories

### (559) 457-2340



INCLUDING THE  
ITEMS ON THE  
FOLLOWING PAGES



## TWO GREAT TRUCK PARTS STORE LOCATIONS IN CENTRAL CALIFORNIA

### Fresno



2645 South Cherry Street • Fresno • CA • 93706

### Shafter



3701 Enterprise Street • Shafter • CA • 93263

## HOME OF THE SCELZI COMPANY STORE



### Caps and Beanies



### Sweatshirts



### Tee Shirts



And Much More...

SCAN this code on your phone to visit our Company Store  
Or go to <http://www.seinc.com/COMPANystore.htm>

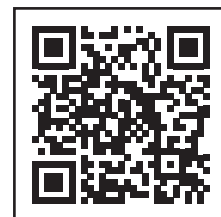







# Parts and Optional Equipment

## For ALL Bodies

	<b>Tool Boxes/Drawers</b>	Page 50
	<b>Polyurea Lining</b>	Page 51
	<b>Backpacks</b>	Page 51
	<b>Hitches</b>	Page 52
	<b>Spare Tire Carrier</b>	Page 52
	<b>Water Cask Holders</b>	Page 52
	<b>Beacon Plate/Pedestal</b>	Page 52
	<b>Vise Stands</b>	Page 53
	<b>Locking Systems</b>	Page 54
	<b>Cranes</b>	Page 55
	<b>Ladder Racks</b>	Page 55
	<b>Lift Gates</b>	Page 55

## For SERVICE Bodies

	<b>Roller Tops</b>	Page 56
	<b>Trailer Plugs</b>	Page 56

Tool Boxes

Toolboxes are available in Black or White as standard

**Closed Top**

Scelzi Top Mount, Closed Top model

LONG	HIGH	DEEP
72"	18"	18"
96"	18"	18"
108"	18"	18"



**Open Top**

Scelzi Top Mount, Open Top model

LONG	HIGH	DEEP
48"	18"	18"
72"	18"	18"
96"	18"	18"
108"	18"	18"



**Underbody**

LONG	HIGH	DEEP
24"	18"	18"
30"	18"	18"
36"	18"	18"
40"	18"	18"
48"	18"	18"
60"	18"	18"



Open Top Black Toolbox With Optional Dividers



## Modular Tool Drawer Systems



Just Press Down to Pull Out - the Best gets even BETTER

- Available in 3" through 8" High Heavy Duty Drawers
- 250# Test
- Galvanized Steel only
- Drawer Dividers sold separately



## Back Packs

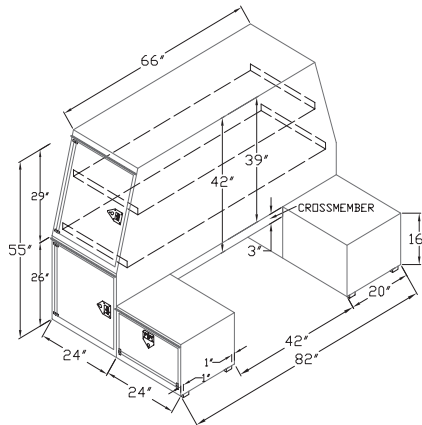
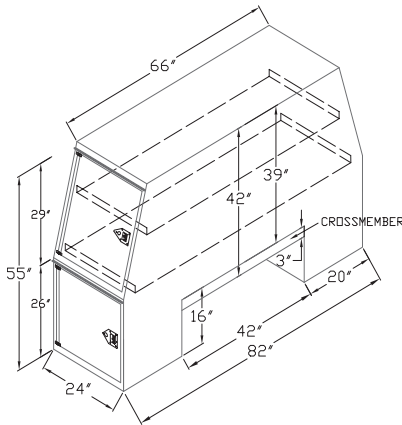

## Scelzi Tool Box Roller Trays

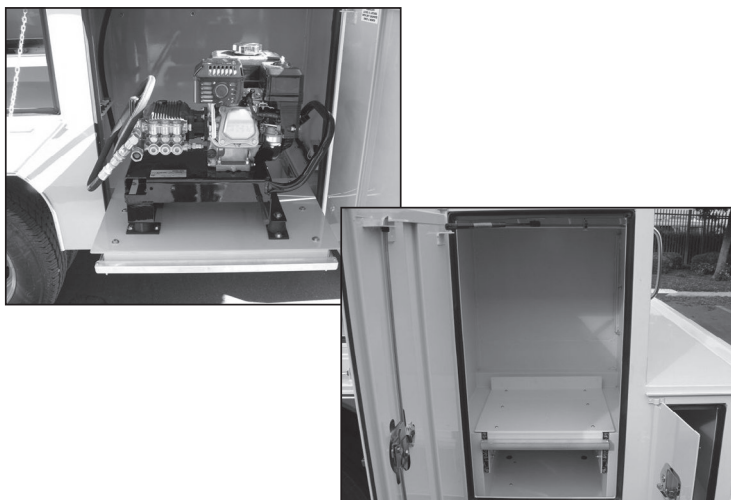

## Polyurea Lining

Non-slip surfacing for beds and bumpers



## Water Cask Holders

Standard Water Cask Holder With Strap  
PART NO SE190015

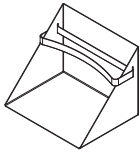

Ring Style Water Cask Holder  
PART NO SE190014

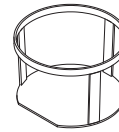

## Spare Tire Carriers

**PART #SE143000**  
UNDERBODY SPARE TIRE CARRIER

-FORD F-350-550 DRW,  
DODGE 3500-5500 DRW  
-CAN BE USED ON FREIGHTLINER  
AND INTERNATIONAL  
LOW PROFILE MODELS  
(MAXIMUM TIRE DIAMETER 34")

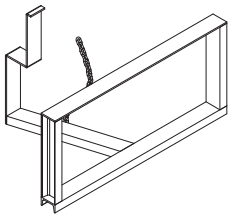

NOTE: MUST BE LOCATED ON DRIVER SIDE  
WILL NOT WORK WITH MIDSHIP  
OR DUAL TANK CONFIGURATIONS

**PART #SE143001**  
UNDERBODY SPARE TIRE CARRIER

FOR CLASS 5-7 CONVENTIONAL CAB  
(IE FREIGHTLINER M2) (11R 22.5 TIRES)  
(MAXIMUM TIRE DIAMETER 42 1/2")

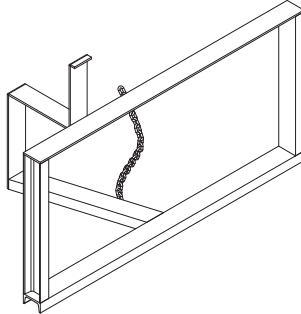

NOTE: NOT FOR USE ON VEHICLES WITH 12R22.5 TIRES  
TIRE SIZE MUST BE NOTED ON WORK ORDER

UNDERBODY SPARE TIRE CARRIER -  
DRIVER SIDE APPLICATION SHOWN

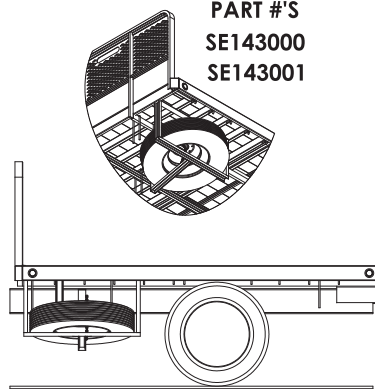

PART #'S  
SE143000  
SE143001

VERTICAL SPARE TIRE HOLDER

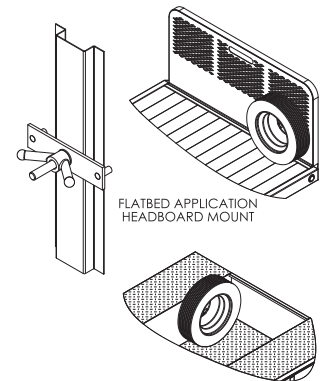

FLATBED APPLICATION  
HEADBOARD MOUNT

SERVICE BODY APPLICATION  
BACKWRAPPER MOUNT

## Beacon Plates and Pedestals

**SE091020**

BEACON PLATE, 9" X 9"

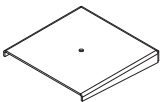

**SE091021**

BEACON PLATE, 7" X 7"

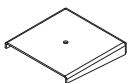

**SE091022**

MINI LIGHTBAR PLATE, 9" X 18"

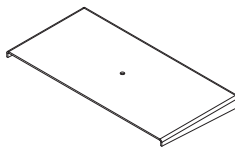

**SE192034**

BEACON PEDESTAL, 7" X 7"  
PLATE, FOR 38" TALL BODY

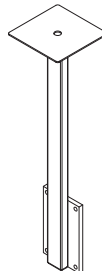

BODY HEIGHT	PART NUMBER
33" TALL BODY	SE192033
38" TALL BODY	SE192034
43" TALL BODY	SE192035
60" TALL BODY	SE192037

**SE192031**

BEACON PEDESTAL, 9" X 9"  
PLATE, FOR 38" TALL BODY

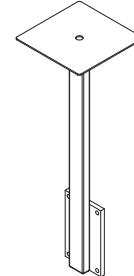

BODY HEIGHT	PART NUMBER
33" TALL BODY	SE192030
38" TALL BODY	SE192031
43" TALL BODY	SE192032
60" TALL BODY	SE192036

## Hitches

**Receiver Hitches**



CLASS 4 - 10,000#  
Capacity, 1000#  
Tongue Weight

CLASS 5 - 18,000#  
Capacity, 1,800#  
Tongue Weight

**Dump Hitches**



CLASS 4 - 10,000#  
Capacity, 1000#  
Tongue Weight

CLASS 5 - 18,000#  
Capacity, 1,800#  
Tongue Weight

Vise Stands

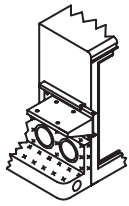

Bolt On Stainless Steel Panel

SSV-128

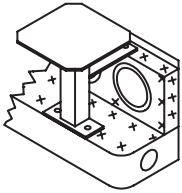
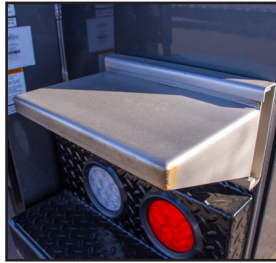

Standard Vise Stand Non-Removeable 9" x 9" Plate

SVS-121



--

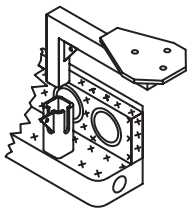

Lockable Vise Stand With Removeable Plates  
 •Small BC210 or  
 •Large BC410 (PG & E style)

LVSR-210  
 LVSR-410

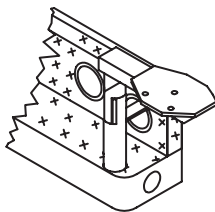
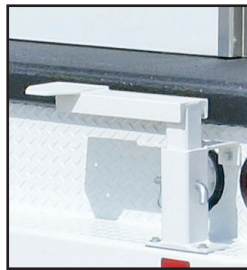

Swivel Base Vise Stand With Removeable Plates  
 •Small BC210 or  
 •Large BC410

SWV-127

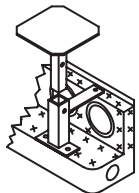

Vise Stand with Removeable 9" x 9" Plate

VSR-123

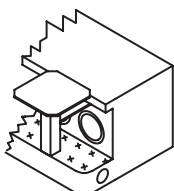

Weld Vise Stand On Work Deck or Bumper Non-powder coated

VSW-122

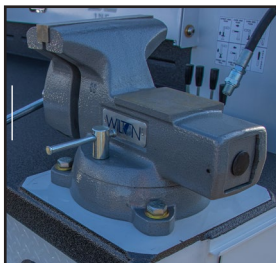

Vise Not Included

PIPE HOLDERS

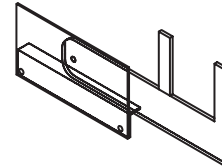

Pipe Holder Between Cab and Body

PH-124

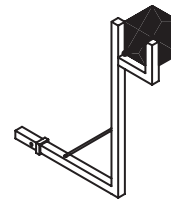

Front Bumper Pipe Holder WITH Bucket

BPH-126

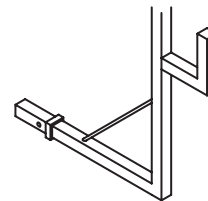

Front Bumper Pipe Holder Without Bucket

BPH-125



Electronic Locking Systems

**Scelzi Electronic Locking System®**

Covered under patent #8,869,576 B2

Rotary electronic master lock system provides additional protection for service body compartments in addition to the Scelzi locking T-handles. The Scelzi Electronic Locking System® can be used with an auxiliary remote or can be tied in to the factory electronic door locking system if the chassis is equipped with the automatic door lock option. The system utilizes an electronic actuator to activate a rotating rod to positively lock a cam system to the door. This provides a remote system to enhance the body security without the addition of parts protruding to the outside of the body.

The system is available on all standard service bodies -- contact your factory representative for availability on other body styles.

For both Electronic and Manual systems, a rotating rod is activated to lock a cam system to the door.



Can be programmed into the truck's cab security key for ease of use.



Electronic actuator. When activated the patented locking system rotates the rod and cam system

Heavy duty cam and hook

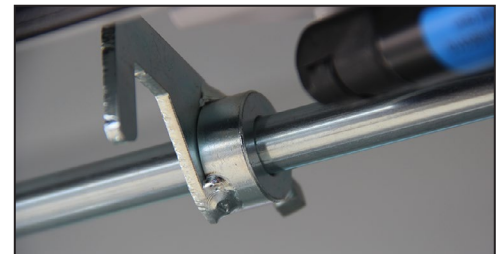

**Scelzi Manual Master Lock System\***

Manual master lock system provides an independent locking system to increase vehicle security above the level offered by traditional compartment locks. The system utilizes a positive lock cam system controlled by a stainless steel handle located on the rear of each service body side pack. The handle is then secured in the locked position with a padlock. All hardware provided is stainless steel or zinc coated for enhanced corrosion protection.

The system is available on all standard service bodies, for applications relating to custom and crane bodies contact your factory representative.

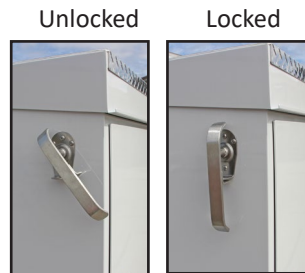

When manually activated the locking system rotates the rod and cam system that hooks into the door



\* Proprietary Scelzi Design

## Ladder Racks

Non - Forklift Accessible  
Ladder Rack

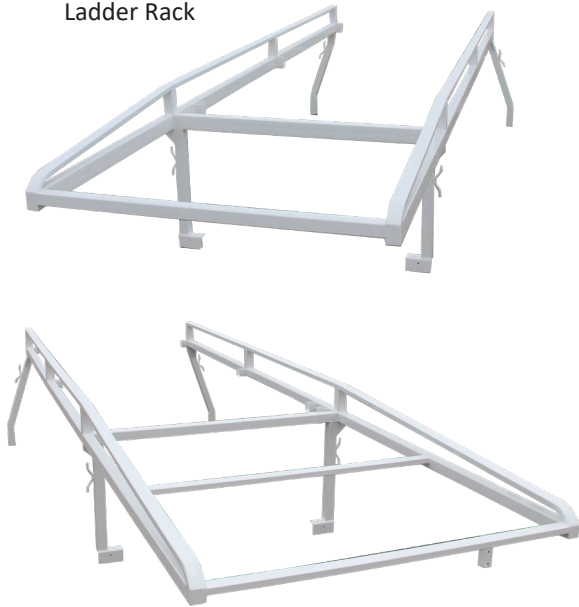

Standard - Forklift Accessible  
Ladder Rack



## Cranes and Lift Gates



## Miscellaneous Holders and Accessories



Cone  
Holders



Tamper Holder



Steps and Handles

## Roller Tops

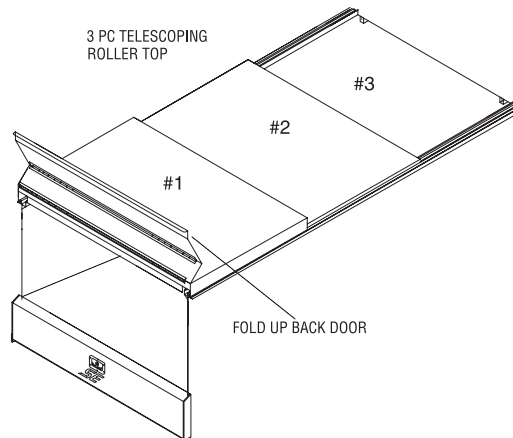
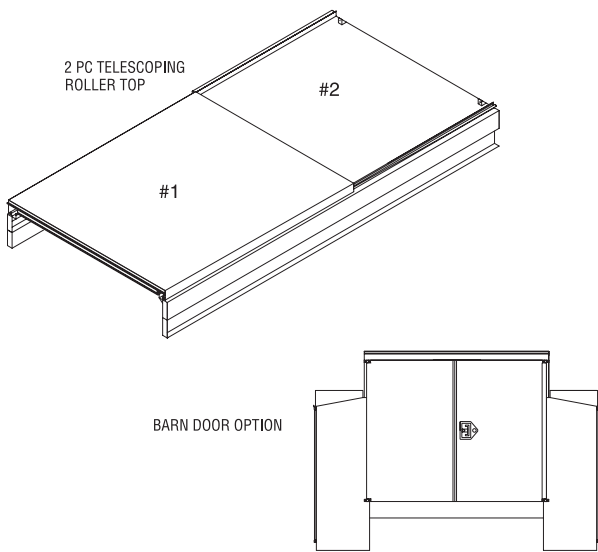

Roller Tops come with stainless steel track and rollers.

\* Note: Can be raised from 3" to 14" for an additional charge.



### 2-PIECE ROLLER TOP

Available for bodies of 80", 98" or 108" long

### 3-PIECE ROLLER TOP

Available for bodies of 98", 108", 132" or 156" long

Comes standard with fold up back door that includes overlapping tailgate for locking. Can be raised from 3" up to 14" tall and can be ordered with barn doors.



## Trailer Plugs



No. 11-410  
4 Pin - Cole Hersey  
Chrome



No. 12063  
7 Pin - Round Plug



No. 1235  
6 Pin - Cole Hersey  
Plug



No. 12707  
7 Pin - Flat RV Plug





# Scelzi Classics

*These truck bodies are still available with Extended Lead Times*

**SCELZI CLASSICS**

## Contour Service Bodies



Premium Quality Service Bodies with unique contoured edges and corners. Contour ladder rack, conduit boxes open on top, standard vise stand and receiver hitch. The top-of-the-line Service Body.

Model	Length	CA	Compartment Height	Rear Wheel
CSB-98	98 inches	56	38 "	Single
CSB-108	108 inches	60	38"	Dual



## CRUISER Body

11 ft long

(108 CA)

Stylish 11 foot long (132 inches) Cruiser Body with hand rail and 5th wheel hitch under removeable steel cover in aluminum bed.





# Scelzi Hall of Fame

Recent Inductees

*Chevrolet*



247590

*Chevrolet*



248367

*Ford*



224709

*Ford*



242484

*Ram*



243147

*Ram*



235091

HALL OF FAME



# Custom Bodies



Custom 8 ft x 10.6 ft flatbed



Custom flatbed with Scorpion Attenuator



Custom 8 ft x 15 ft Cone Body



Custom SBD-108

CUSTOM BODIES

Please Note: Custom Bodies Require Extended Lead Times



# SCELZI Enterprises Incorporated

Premium Truck Body Manufacturing

*Building An American Legacy One Truck Body At A Time*



**The Scelzi Enterprises Fleet**



GENERAL MOTORS FLEET  
SPECIAL VEHICLE MANUFACTURER



[www.seinc.com](http://www.seinc.com)



## Pool Locations

### *Fresno*

Scelzi Enterprises, Inc.  
Corporate Headquarters  
2286 East Date Avenue  
Fresno, CA. 93706  
Office: (559) 237-5541  
Toll Free: (800) 858-2883  
Fax: (559) 237-5554

### *Denver*

Scelzi Enterprises, Inc.  
203 5th Avenue  
La Salle, CO 80645  
Office: (559) 237-5541  
Toll Free: (800) 858-2883  
Fax: (559) 496-3202

### *Riverside*

Scelzi Enterprises, Inc.  
2693 Rubidoux Blvd.  
Riverside, CA 92509  
Office: (559) 237-5541  
Toll Free: (800) 858-2883  
Fax: (559) 496-3202

### *Shafter*

Scelzi Enterprises, Inc.  
3701 Enterprise Street  
Shafter, CA. 93263  
Office: (559) 237-5541  
Toll Free: (800) 858-2883  
Fax: (559) 496-3202

### *Washington*

Scelzi Enterprises, Inc.  
2219 112th Street East  
Tacoma, WA 98445  
Office: (559) 237-5541  
Toll Free: (800) 858-2883  
Fax: (559) 496-3202